



HEALTHCARE SERVICES

Medical Gases Catalog

For Use in United States Only

Gases

Equipment

Services

Reference Data

*To order product, call your local branch or dial
1-800-PRAXAIR*

*Praxair can also be found on the Internet
<http://www.praxair.com/healthcare>*



Electronic and Print Catalog, U.S. Table of Contents

Pure Gases in High Pressure Cylinders

- Introduction
- Oxygen U.S.P.
- Grab'nGo® Vantage
- Medical Air U.S.P.
- Nitrous Oxide U.S.P.
- Carbon Dioxide U.S.P.
- Helium U.S.P.
- Nitrogen N.F.

Pure Gases in Liquid Cylinders

- Introduction
- Oxygen U.S.P. Cryogenic Liquid
- Carbon Dioxide U.S.P. Refrigerated Liquid
- Nitrogen N.F. Cryogenic Liquid

Medical Gas Mixtures

- Introduction
- Biological Atmospheres (Anaerobic)
- Biological Atmospheres (Aerobic)
- Blood Gas Calibration
- Heliox (Helium/Oxygen Mixtures)
- Grab'nGo® Heliox
- Medical Laser
- Medical Gas Mixtures
- Lung Diffusion

Bulk Gases

Hyperbaric Oxygen

Liquid Helium for MRI

Dry Ice

Equipment

Accessories

- Accessories for High Pressure Cylinders
- Accessories for Cryogenic Containers

Hoses

- Hose Assemblies

Manifolds

- Fully Automatic Manifolds

Storage Cabinets

- Cylinder Storage Cabinets

Regulators

- Adjustable Regulator with Flow Gauge
- Preset Regulator with Pressure Gauge
- Adjustable Regulator with Pressure Gauge
- Click Style Regulator
- Regulator for Medical Gas Mixtures
- Regulator for Helium/Oxygen Mixtures
- Regulator for Flammable, Anaerobic Gas Mixtures
- MRI Compatible Medical Gases and Equipment

Flowmeters

- Adult Flowmeter
- Pediatric Flowmeter

Suction Regulators

- Introduction to Suction Drainage Equipment
- Suction Regulators
- Remote Safety Interrupter
- Accessories for Suction Equipment

Cryogenic Products

- Introduction to Cryogenic Products
- High Efficiency Freezers
- Stock Series Freezers
- Cryo-Preservation Freezers
- Freezers
- Dewars
- Hand Held Cryo Freezing Devices

Services

- Medical Gases Pipeline Equipment Sales and Service
- Brazing Program
- Turnkey Solutions for Piping Systems
- Maintenance Program for Piping Systems
- Environmental Monitoring Services
- Site Gas Services
- Analytical Services

Physicians and Dentists

- Cryogenic Products for Primary Care
- Accessories for Physicians and Dentists

Safety and Reference Data

- Cylinder Valve Connections
- Post Type Pin Indexed Yoke Valves
- Threaded Outlet Type Valves with Handwheels
- Cylinder Sizes and Color Chart
- General Safety Information

Pure Medical Gases in High Pressure Cylinders



Medipure[®]
Medical Gases

Praxair's *Medipure*[®] Cylinder Gases

Praxair offers a full line of pure medical gases in high-pressure cylinders distributed under the *Medipure*[®] trademark, your assurance of quality and purity.

Praxair's *Medipure*[®] pure medical gases, classified by Food and Drug Administration (FDA-USA) as drugs, are produced in accordance with Good Manufacturing Practices (GMP). All pure medical gases meet U.S.P. / N.F. requirements and are produced in accordance with Praxair's high quality standards.

Praxair facilities are audited both internally and by FDA.

While Praxair's pure high-pressure medical gas cylinders are color-coded, their contents should be verified before use by carefully reading the product label, and should be used only by or under the supervision of a licensed practitioner. Adapters must never be used to hookup a medical gas cylinder.

Pure Medical Gases listed in this section are:

- Medical Air U.S.P.
- Carbon Dioxide U.S.P.
- Helium U.S.P.
- Nitrogen N.F.
- Nitrous Oxide U.S.P.
- Oxygen U.S.P.

Purchasing managers have already made Praxair one of the leading suppliers of medical gases in North America. The *Medipure*[®] brand introduces a new generation of commitment to superior quality products, service and support.

On the following pages, you will find an easy reference to safety and technical information about our pure gases. Technical references include:

- Molecular Weight, Critical Temperature, Pressure and Boiling Point
- DOT Designation, Label and Hazard Classification
- Purity Specifications
- CGA Connection
- Cylinder Ordering information, Cylinder Sizes and Nominal Contents
- Equipment Recommendations

Oxygen U.S.P. Portable Cylinder Sizes

High-Pressure Cylinders

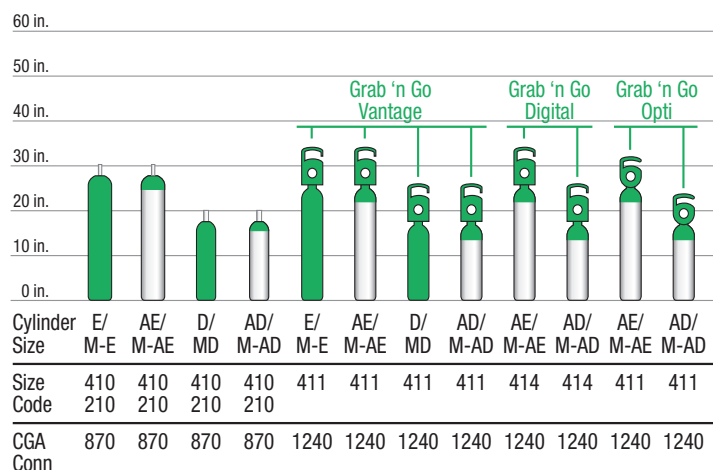

Major Hazards: Fire and High Pressure
 Toxicity: Nontoxic
 Fire Potential: Highly Oxidizing
 Boiling Point (°F): -297.4
 Molecular Weight: 32.00
 Specific Gravity: 1.105
 Critical Temperature (°F): -181.5
 Critical Pressure (psia): 731.4
 Specific Volume (cf/lb): 12.1
 UN No.: 1072
DOT Designation
 Name: Oxygen, Compressed
 Label: Yellow Oxidizer
 Hazard Classification: 2.2

CGA Connection No. 870

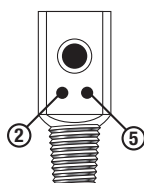

Post type pin indexed valves

PURITY SPECIFICATIONS

Purity: Oxygen \geq 99.0% CO₂ \leq 300ppm
 Odor: None CO \leq 10ppm

MSDS

P-4638

CYLINDER SPECIFICATIONS

Equipment Recommendations

Ordering Number	Cyl Size	Cyl Type	Nominal Contents	Press (psig) @ 70°F	CGA Conn	Regulator
OX M-E	M-E	Steel	25 cu ft	2000	870	WESOPA-870 WESM1-870-15FG WESM1-870-8FG
OX M-AE	AE	Aluminum	24 cu ft	2000	870	WESOPA-870 WESM1-870-15FG WESM1-870-8FG
OX M-D	M-D	Steel	15 cu ft	2000	870	WESOPA-870 WESM1-870-15FG WESM1-870-8FG
OX M-AD	AD	Aluminum	15 cu ft	2000	870	WESOPA-870 WESM1-870-15FG WESM1-870-8FG
OX M-EGNGVNTG	M-E	Steel	25 cu ft	2000	NR	Grab'nGo-Vantage (Regulator Included)
OX M-AEGNGVNTG	M-AE	Aluminum	24 cu ft	2000	NR	Grab'nGo-Vantage (Regulator Included)
OX M-DGNGVNTG	M-D	Steel	15 cu ft	2000	NR	Grab'nGo-Vantage (Regulator Included)
OX M-ADGNGVNTG	M-AD	Aluminum	15 cu ft	2000	NR	Grab'nGo-Vantage (Regulator Included)
OX M-AEGNGDIGIT	M-AE	Aluminum	24 cu ft	2000	NR	Grab'nGo-Digital (Regulator Included)
OX M-ADGNGDIGIT	M-AD	Aluminum	15 cu ft	2000	NR	Grab'nGo-Digital (Regulator Included)
OX M-AEGNGOPTI	M-AE	Aluminum	24 cu ft	2000	NR	Grab'nGo-Opti (Regulator Included)
OX M-ADGNGOPTI	M-AD	Aluminum	15 cu ft	2000	NR	Grab'nGo-Opti (Regulator Included)

Color Code:

Shoulder Color: Green

Body Color: Steel, Painted Green
 Aluminum, Unpainted

Medical Applications

Used in first-aid treatment of emergencies such as suffocation and heart attacks; in the treatment of patients with respiratory disorders; in anesthesia; in hyperbaric oxygen chambers for the treatment of carbon monoxide poisoning and gas gangrene, and for other specialized oxygen therapies.



PRAXAIR
Grab 'n Go®

**Grab 'n Go® Digital Respiratory System –
“So Smart it Speaks for Itself”**

A patient is scheduled for an MRI and an oxygen cylinder is available, but you are not sure how long it will last. Do you swap it out and potentially waste gas? Or, do you continue with transport? Meanwhile, the patient is waiting and schedules are delayed. Don't let this happen in your hospital.

Now, transport your patients with added confidence with the Grab 'n Go Digital. Featuring an easy-to-read digital display of oxygen time remaining in hours and minutes that automatically adjusts for flow. Audible and visual alarms increase efficiency and reliability by alerting you to low content and when to swap for full cylinder.

Whether you are looking to facilitate a rapid transport or you're in a primary care setting and need to respond to an in-office emergency, the Praxair *Grab 'n Go* is the oxygen cylinder hospitals grab for.

- **Digital Display Includes Auto-Calculator**
Quick-read feature provides alternating cylinder contents pressure and oxygen time remaining in hours and minutes based on selected flow rate.
- **Audible and Visible Alerts**
Large color coded pressure display on dial face is coupled with a visual and audible alarm to alert you when it is time to switch to another full system.
- **Easy to read and adjust flow settings**
The snap-set flow-adjusting control knob allows you to control oxygen flow at settings most frequently prescribed.
- **Ergonomic handle and light weight construction**
An ergonomically designed handle and light composit material makes the system easy to manage and transport.
- **Rugged Lexan® construction provides protection**
A tough Lexan® plastic cover protects the regulator in the event of a drop or fall. This cover meets the ISO 11117 Drop Test requirement.
- **Flexible use via hose barb or 50 psi auxiliary connection**
The *Grab 'n Go* Digital system facilitates moving a patient with a ventilator. A 50 psig auxiliary connection to supply demand valves or portable ventilators delivers up to 100 lpm.
- **Simplified inventory**
With the regulator and flowmeter built-in and maintained by Praxair, there is less equipment to worry about saving money and time.

MRI Compatible Design:

Grab 'n Go Digital System is certified MRI Contingent to 3-Tesla, when located outside the MR bore.

Additional savings include increased diagnostic revenues from more timely patient transport, efficient use of oxygen cylinder contents, and a shorter learning curve for your staff.

Thousands of *Grab 'n Go* Digital systems are in use at hundreds of health care facilities throughout the U.S. and Canada. These portable units are available from more than 300 Praxair locations in North America.

Call Praxair to schedule an evaluation of your cylinder needs today! 1-800-PRAXAIR



PRAXAIR
Grab 'n Go[®]

Thousands of Grab 'n Go systems are in use at hundreds of health care facilities throughout the U.S. and Canada.

These portable units are available from more than 300 Praxair locations in North America.

Greater than
750 psi



Less than
750 psi



Grab 'n Go[®] Opti Respiratory System

Compact. Lightweight. Equipped with new, glow in the dark contents indicator.

The grab 'n go Opti is our lightest and most compact portable oxygen system featuring new technology to help caregivers evaluate cylinder contents – at a distance.

The Grab 'n Go Opti system includes all the standard advantages you've come to expect from our award winning grab 'n Go systems and more, in a compact lighter-weight design.

- **Easy-to-read contents indicator**
Visible through the clear window on the side of the shroud, the contents indicator begins to turn red once the cylinder contents reach 750 psi, and is fully red at 500 psi when it is time to change the cylinder to a full one.
- **Glow-in-the-dark pressure gauge**
Since portable oxygen systems may be used under low-light conditions, the pressure gauge incorporates glow in the dark material to make it easier to read.
- **Two-valve single-knob control activation**
Streamlines training vs. units that require 2 knobs to be turned to initiate the flow.
- **Ergonomic handle and light weight construction**
An ergonomically designed handle and light composite material makes the system easy to manage and transport.
- **Tough impact resistant shroud**
A protects the regulator in the event of a drop or fall and meets the ISO 11117 Drop Test requirement.
- **Flexible use via hose barb or 50 psi auxiliary connection**
The *Grab 'n Go Opti* system can accommodate a slim-fit tubing and nasal cannula or can be used to attached to equipment via the auxiliary connection.
- **Simplified inventory**
With the regulator and flowmeter built-in and maintained by Praxair, there is less equipment to worry about saving money and time.

MRI Compatible Design:
Grab 'n Go Digital System is certified MRI Contingent to 3-Tesla, when located outside the MR bore.

Oxygen U.S.P. Stationary Cylinder Sizes

High-Pressure Cylinders

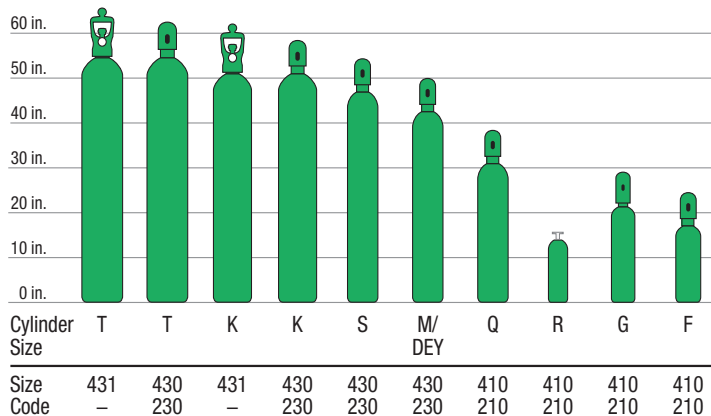

CGA Connection No. 540

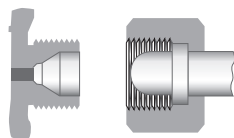

Threaded outlet type valves

Major Hazards: Fire and High Pressure
 Toxicity: Nontoxic
 Fire Potential: Highly Oxidizing
 Boiling Point (°F): -297.4
 Molecular Weight: 32.00
 Specific Gravity: 1.105
 Critical Temperature (°F): -181.5
 Critical Pressure (psia): 731.4
 Specific Volume (cf/lb): 12.1
 UN No.: 1072
DOT Designation
 Name: Oxygen, Compressed
 Label: Yellow Oxidizer
 Hazard Classification: 2.2

PURITY SPECIFICATIONS

Purity: Oxygen \geq 99.0% CO₂ \leq 300ppm
 Odor: None CO \leq 10ppm

MSDS

P-4638

CYLINDER SPECIFICATIONS

Equipment Recommendations

Ordering Number	Cyl Size	Nominal Contents	Press (psig) @ 70°F	CGA Conn	Regulator
OX M-Q	Q	83 cu ft	2200	540	WESM1-540-PG , WESM1-540-P, WESM1-540-15FG , WESM1-540-8FG
OX M-S	S	154 cu ft	2200	540	WESM1-540-PG , WESM1-540-P, WESM1-540-15FG , WESM1-540-8FG
OX M-K	K	249 cu ft	2200	540	WESM1-540-PG, WESM1-540-P, WESM1-540-15FG , WESM1-540-8FG
OX M-T	T	337 cu ft	2640	540	WESM1-540-PG , WESM1-540-P, WESM1-540-15FG , WESM1-540-8FG
OX M-K-LC	K	249 cu ft	2200	DISS 1080	Regulator included
OX M-T-LC	T	337 cu ft	2640	DISS 1080	Regulator included

Color Code:

Shoulder Color: Green

Body Color: Steel, Painted Green

Medical Applications

Used in first-aid treatment of emergencies such as suffocation and heart attacks; in the treatment of patients with respiratory disorders; in anesthesia; in hyperbaric oxygen chambers for the treatment of carbon monoxide poisoning and gas gangrene, and for other specialized oxygen therapies.

Praxair, the Flowing Airstream design, Medipure and Grab 'n Go are trademarks or registered trademarks of Praxair Technology, Inc. in the United States and/or other countries. Other trademarks used herein are property of their respective owners. The information contained herein is offered for use by technically qualified personnel at their discretion and risk without warranty of any kind. © Copyright 2016, Praxair Technology, Inc. All rights reserved. Praxair Inc., Danbury, CT 06810-5113

Medical Air U.S.P.

Colorless, odorless, nonflammable gas

High-Pressure Cylinders

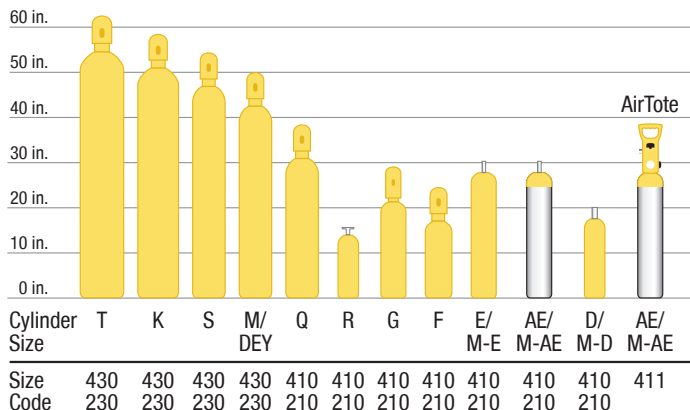

Major Hazards: High Pressure
 Toxicity: Nontoxic
 Fire Potential: Supports Combustion
 Boiling Point (°F): -317.8
 Molecular Weight: 28.96
 Specific Gravity: 1
 Critical Temperature (°F): -221.1
 Critical Pressure (psia): 546.85
 Specific Volume (cf/lb): 13.3
 UN No.: 1002

DOT Designation

Name: Air, Compressed
 Label: Green, Nonflammable Gas
 Hazard Classification: 2.2

CGA Connection No. 346

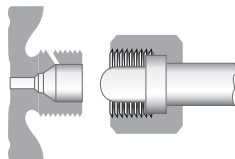

CGA Connection No. 950

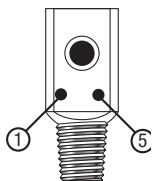

PURITY SPECIFICATIONS

Purity: Oxygen 19.5-23.5%
 Balance Nitrogen
 Odor: None

water and oil: none
 $SO_2 \leq 5\text{ppm}$
 $NO+NO_2 \leq 2.5\text{ppm}$
 $CO \leq 10\text{ppm}$
 $CO_2 \leq 500\text{ppm}$

MSDS

P-4560

CYLINDER SPECIFICATIONS

Equipment Recommendations

Ordering Number	Cylinder Size	Nominal Contents	Pressure (psig) @ 70°F	CGA Connection	Regulator
AI M-D	M-D	14 cu ft	2000	950	WESM1-950-PG
AI M-E	M-E	23 cu ft	2000	950	WESM1-950-PG
AI M-AE	AE	22 cu ft	2000	950	WESM1-950-PG
AI M-K	K	232 cu ft	2200	346	WESM1-346-PG WESM1-346-P
AI M-T	T	310 cu ft	2640	346	WESM1-346-PG WESM1-346-P
AI M-AEAIROTOTE	AE	22 cu ft	2000	NR	AirTote, Aluminum (Regulator Included)

Color Code:

Shoulder Color: Yellow

Body Color: Yellow

Medical Applications

Respiratory therapy; humidity treatments using nebulizers, and a source of pneumatic pressure to power gas-operated medical devices.

AirTOTE is a trademark of Western Medica



Nitrous Oxide U.S.P.

Colorless, oxidizing, liquefied gas with a slightly sweetish taste and odor

High-Pressure Cylinders

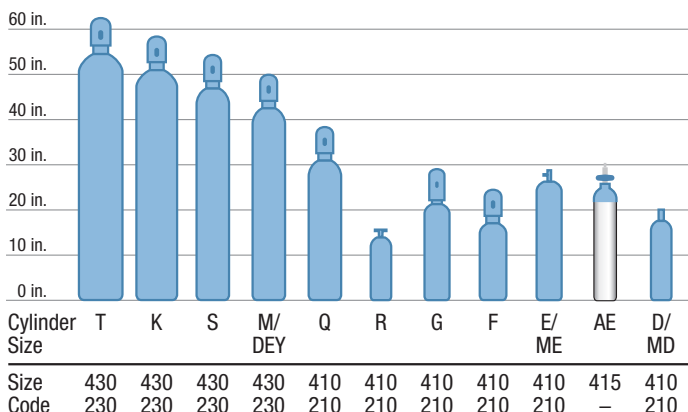

Major Hazards: Fire and High Pressure
 Toxicity: Nontoxic Anesthetic
 Fire Potential: Oxidizer
 Boiling Point (°F): -127.3
 Molecular Weight: 44.01
 Specific Gravity: 1.53
 Critical Temperature (°F): 97.7
 Critical Pressure (psia): 1052.2
 Specific Volume (cf/lb): 8.7
 UN No.: 1070
DOT Designation
 Name: Nitrous oxide
 Label: Nonflammable Gas, Oxidizer
 Hazard Classification: 2.2

CGA Connection No. 326

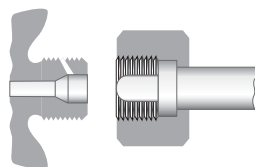

Threaded outlet type valves

CGA Connection No. 910

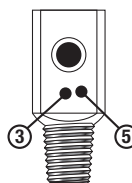

Post type pin indexed valves

PURITY SPECIFICATIONS

Purity: Nitrous Oxide $\geq 99.0\%$
 Odor: Slightly Sweet

Air $\leq 1\%$
 CO₂ $\leq 300\text{ppm}$
 NO $\leq 1\text{ppm}$
 NO₂ $\leq 1\text{ppm}$
 NH₃ $\leq 25\text{ppm}$
 Halogens $\leq 1\text{ppm}$
 CO $\leq 10\text{ppm}$
 H₂O $\leq 200\text{ppm}$

MSDS

P-4636

CYLINDER SPECIFICATIONS

Equipment Recommendations

Ordering Number	Cylinder Size	Nominal Contents	Pressure (psig) @ 70°F	CGA Connection	Regulator
NS M-D	M-D	3.9 lb	745	910	WESM1-910-PG
NS M-E	M-E	6.4 lb	745	910	WESM1-910-PG
NS M-20	20 lb	20 lb	745	326	WESM1-326-PG WESM1-326-P
NS M-50	K	50 lb	745	326	WESM1-326-PG WESM1-326-P
NS M-64	K	64 lb	745	326	WESM1-326-PG WESM1-326-P
NS M-AEALERT	M-AE	6.4 lb	745	910	Content gauge permanently attached, WESM1-910-PG or equivalent

Color Code:

Shoulder Color: Blue

Body Color: Blue

Medical Applications

As an analgesic, often in combination with other agents for the production of anesthesia. Nitrous Oxide is also used in cryosurgery.

Praxair, the Flowing Airstream design, Medipure and Grab 'n Go are trademarks or registered trademarks of Praxair Technology, Inc. in the United States and/or other countries. Other trademarks used herein are property of their respective owners. The information contained herein is offered for use by technically qualified personnel at their discretion and risk without warranty of any kind. © Copyright 2016, Praxair Technology, Inc. All rights reserved. Praxair Inc., Danbury, CT 06810-5113

Carbon Dioxide U.S.P.

Colorless, odorless, nonflammable, slightly acidic, liquefied gas

High-Pressure Cylinders

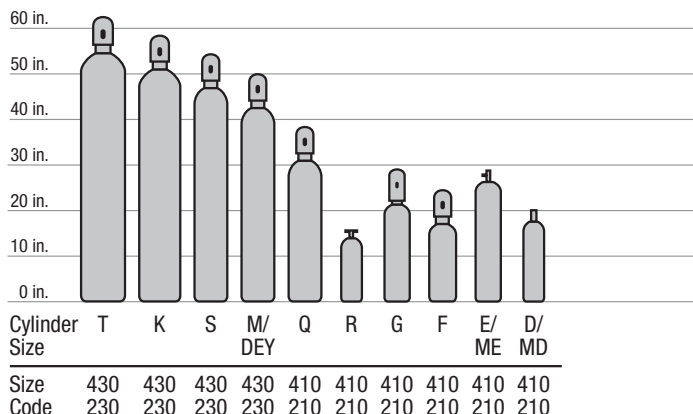

Major Hazards: High Pressure and Inhalation
 Toxicity: Low Toxicity, TLV of 5000ppm
 Fire Potential: Nonflammable
 Boiling Point (°F): -109.1
 Molecular Weight: 44.01
 Specific Gravity: 1.522
 Critical Temperature (°F): 87.8
 Critical Pressure (psia): 1070.6
 Specific Volume (cf/lb): 8.76
 UN No.: 2187

DOT Designation

Name: Carbon Dioxide
 Label: Green, Nonflammable Gas

Hazard Classification: 2.2

CGA Connection No. 320

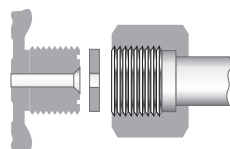

Threaded outlet type valves

CGA Connection No. 940

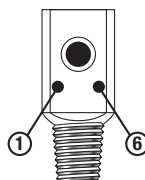

Post type pin indexed valves

PURITY SPECIFICATIONS

Purity: Carbon Dioxide \geq 99.0%
 Odor: None
 $CO \leq 10\text{ppm}$
 $NO \leq 2.5\text{ppm}$
 $NH_3 \leq 25\text{ppm}$

MSDS

P-4574
 $H_2O \leq 200\text{ppm}$
 $NO_2 \leq 2.5\text{ppm}$
 $H_2S \leq 1\text{ppm}$
 $SO_2 \leq 5\text{ppm}$

CYLINDER SPECIFICATIONS

Equipment Recommendations

Ordering Number	Cylinder Size	Nominal Contents	Pressure (psig) @ 70°F	CGA Connection	Regulator
CD M-D	M-D	4 lb	830	940	WESM1-940-PG
CD M-E	M-E	6 lb	830	940	WESM1-940-PG
CD M-AE	AE	6 lb	830	940	WESM1-940-PG
CD M-Q	Q	20 lb	830	320	WESM1-320-PG WESM1-320-P
CD M-20	20 lb	20 lb	830	320	WESM1-320-PG WESM1-320-P
CD M-50S	50 lb	50 lb	830	320	N/A
CD M-50	K	50 lb	830	320	WESM1-320-PG WESM1-320-P
CD M-64	64 lb	64 lb	830	320	WESM1-320-PG WESM1-320-P

Color Code:

Shoulder Color: Gray

Body Color: Gray

Medical Applications

For close-to-physiologic atmospheres for the operation of artificial organs; in cryosurgery with unsufflators during laparoscopic surgery; and as a component in a mixture of oxygen or air as a respiratory stimulant to promote deep breathing. Syphon cylinders are available on request. A syphon cylinder uses a full length eductor tube to permit withdrawal of liquid phase product.

Helium U.S.P.

Colorless, odorless, nonflammable inert gas

High-Pressure Cylinders

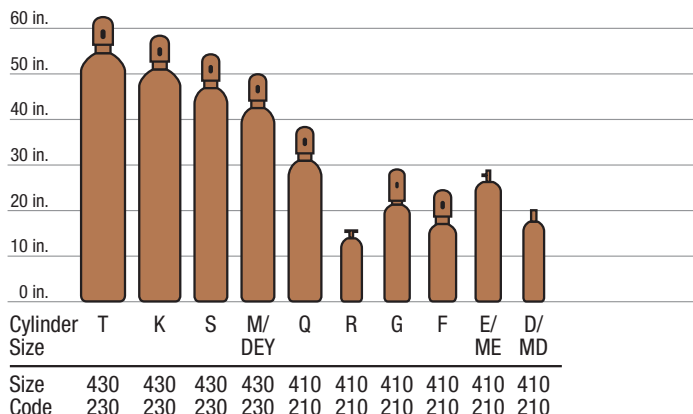

Major Hazards: High Pressure and Asphyxiation
 Toxicity: Nontoxic
 Fire Potential: Nonflammable
 Boiling Point (°F): -452.1
 Molecular Weight: 4.00
 Specific Gravity: 0.138
 Critical Temperature (°F): -450.4
 Critical Pressure (psia): 33.2
 Specific Volume (cf/lb): 96.6
 UN No.: 1046

DOT Designation

Name: Helium, Compressed
 Label: Nonflammable Gas

Hazard Classification: 2.2

CGA Connection No. 580

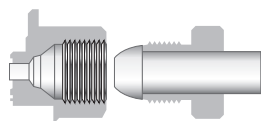

Threaded outlet type valves

CGA Connection No. 930

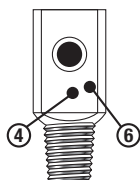

Post type pin indexed valves

PURITY SPECIFICATIONS

Purity: Helium \geq 99.0%
 Odor: None

CO \leq 10ppm
 AIR \leq 1.0%

MSDS

P-4602

CYLINDER SPECIFICATIONS

Equipment Recommendations

Ordering Number	Cylinder Size	Nominal Contents	Pressure (psig) @ 70°F	CGA Connection	Regulator
HE M-D	M-D	13 cu ft	2000	930	WESM1-930-PG
HE M-E	M-E	22 cu ft	2000	930	WESM1-930-PG
HE M-K	K	218 cu ft	2200	580	WESM1-580A-PG

Color Code:

Shoulder Color: Brown

Body Color: Brown

Medical Applications

As a component of breathing mixtures to reduce the density of the mixture and thus facilitate breathing under certain physical and physiological conditions.

Nitrogen N.F.

Colorless, odorless, nonflammable inert gas

High-Pressure Cylinders

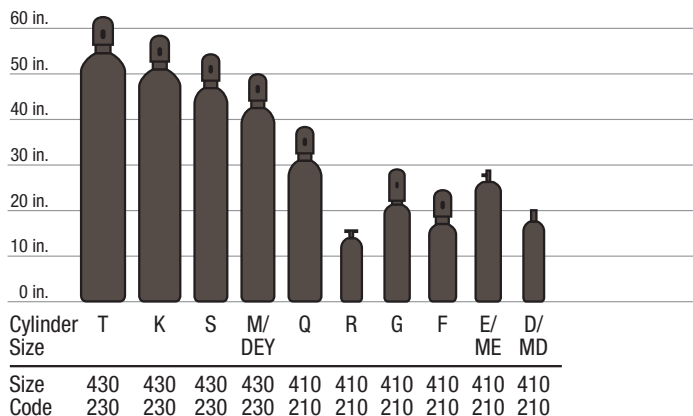

Major Hazards: High Pressure and Asphyxiation
 Toxicity: Nontoxic
 Fire Potential: Nonflammable
 Boiling Point (°F): -320.4
 Molecular Weight: 28.01
 Specific Gravity: 0.97
 Critical Temperature (°F): -237.8
 Critical Pressure (psia): 492.2
 Specific Volume (cf/lb): 13.8
 UN No.: 1066

DOT Designation

Name: Nitrogen, Compressed
 Label: Green, Nonflammable Gas

Hazard Classification: 2.2

CGA Connection No. 580

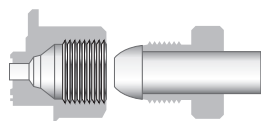

Threaded outlet type valves

CGA Connection No. 960

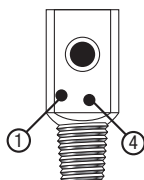

Post type pin indexed valves

PURITY SPECIFICATIONS

Purity: Nitrogen \geq 99.0
 Odor: None

$O_2 \leq$ 1.0%
 $CO \leq$ 10ppm

MSDS

P-4630

CYLINDER SPECIFICATIONS

Equipment Recommendations

Ordering Number	Cylinder Size	Nominal Contents	Pressure (psig) @ 70°F	CGA Connection	Regulator
NI M-D	M-D	14 cu ft	2000	960	WESM1-960-PG
NI M-E	M-E	23 cu ft	2000	960	WESM1-960-PG
NI M-K	K	228 cu ft	2200	580	WESM1-580-PG WESMSH-180-580
NI M-T	T	304 cu ft	2640	580	WESM1-580-PG WESMSH-180-580

Color Code:

Shoulder Color: Black

Body Color: Black

Medical Applications

As a component in many gas mixtures; as a displacement medium in pharmaceutical vials; as a propellant in pressurized aerosol type dispensers; as a coolant for carbon dioxide surgical lasers, and as a source of pneumatic pressure to power gas operated medical devices.

Pure Gases in Liquid Containers



Praxair's *Medipure*[®] Liquefied Mini-bulk Gases

Praxair offers a full line of pure medical gases in liquid cylinders for research diagnostics and inhalation therapy applications. Pure medical gases, classified by Food and Drug Administration (FDA-USA) as drugs, are produced in accordance with current Good Manufacturing Practices (GMP). All pure medical gases meet U.S.P. / N.F. requirements, and are produced in accordance with Praxair's high quality standards.

Praxair facilities are audited both internally and by FDA.

Praxair's pure medical gases in cryogenic containers are clearly labeled with name of the gas contents. These contents should be verified before use by carefully reading the label. These gases should be used only by or under the supervision of a licensed practitioner. Adapters must never be used to connect to a medical gas container.

Pure Medical Gases listed in this section are:

- Carbon Dioxide U.S.P.
- Nitrogen N.F.
- Oxygen U.S.P.

Purchasing managers have already made Praxair one of the leading suppliers of medical gases in North America. The *Medipure*[®] brand introduces a new generation of commitment to superior quality products, service and support.

On the following pages, you will find an easy reference to safety and technical information about our pure gases. Technical references include:

- Molecular Weight, Critical Temperature, Pressure and Boiling Point
- DOT Designation, Label and Hazard Classification
- Purity Specifications
- CGA Connection
- Container Ordering information, Cylinder Sizes and Nominal Contents
- Equipment Recommendations

Oxygen U.S.P. Cryogenic Liquid

Odorless, highly oxidizing, light blue cryogenic liquid

Cryogenic Containers

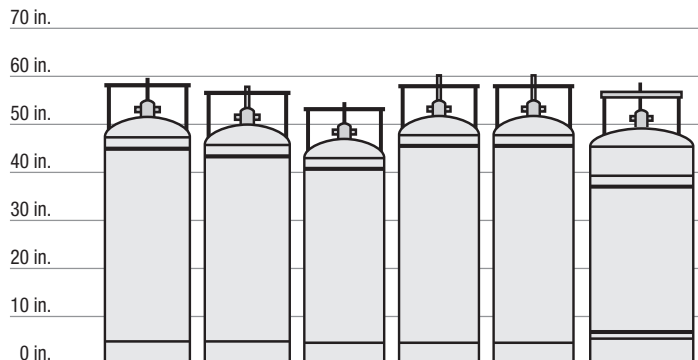

Container Size	HP-180 (GP-55)	HP-160 (GP-55)	LS-160	CD-170	LS-180	XL-230/240
Size	471	471	471	471	471	472
Code	271/274	271/274	271	271	271	272

Major Hazards: Fire and Cryogenic Burns
 Toxicity: Nontoxic
 Fire Potential: Highly Oxidizing
 Boiling Point (°F): -297.4
 Molecular Weight: 32.00
 Specific Gravity: 1.14
 Critical Temperature (°F): -181.5
 Critical Pressure (psia): 731.4
 Specific Volume (cf/lb): 12.1
 UN No.: 1073
DOT Designation
 Name: Oxygen, Refrigerated Liquid
 Label: Yellow Oxidizer
 Hazard Classification: 2.2

PURITY SPECIFICATIONS

Purity : Oxygen \geq 99.0%
 Odor: None

MSDS

$CO_2 \leq$ 300ppm
 $CO \leq$ 10ppm
 P-4637

CYLINDER SPECIFICATIONS

Equipment Recommendations

Ordering Number	Cylinder Size	Nominal Contents	Pressure (psig) @ 70°F	CGA Connection	Regulator
OX MLC160-230	160 L	4580 cu ft	230	GAS 540 / LIQUID 440	WESM1-540-P WESM1-540-PG
OX MLC160-22	160 L	4580 cu ft	22	GAS 540 / LIQUID 440	N/A
OX MLC180-230	180 L	4640 cu ft	230	GAS 540 / LIQUID 440	WESM1-540-P WESM1-540-PG
OX MLC180-22	180 L	4640 cu ft	22	GAS 540 / LIQUID 440	N/A
OX ML230-230	230 L	5930 cu ft	230	GAS 540 / LIQUID 440	WESM1-540-P WESM1-540-PG
OX ML230-22	230 L	5930 cu ft	22	GAS 540 / LIQUID 440	N/A

Color Code :

Shoulder Color: N /A

Body Color : N /A

Medical Applications

Used in first-aid treatment of emergencies such as suffocation and heart attacks; in the treatment of patients with respiratory disorders; in anesthesia; in hyperbaric oxygen chambers for the treatment of carbon monoxide poisoning and gas gangrene, and for other specialized oxygen therapies

Carbon Dioxide U.S.P. Refrigerated Liquid

Colorless, odorless, nonflammable, slightly acidic, refrigerated liquid

Cryogenic Containers

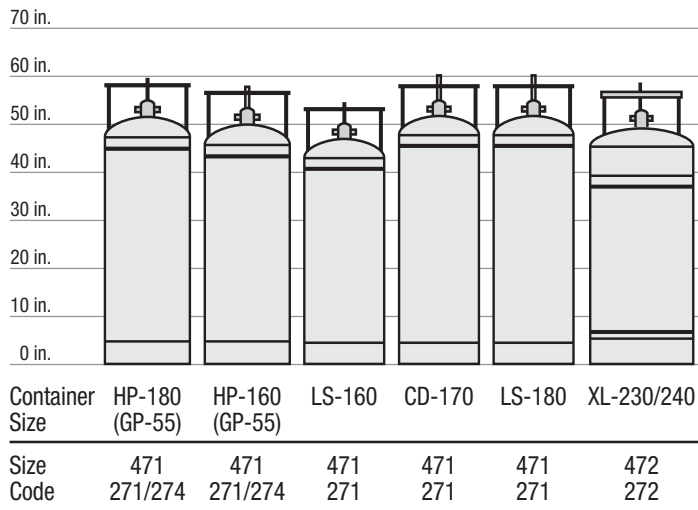

Major Hazards: High Pressure and Inhalation
 Toxicity: Low Toxicity, TLV of 5000ppm
 Fire Potential: Nonflammable
 Boiling Point (°F): -109.1
 Molecular Weight: 44.01
 Specific Gravity: 1.522
 Critical Temperature (°F): 87.8
 Critical Pressure (psia): 1071.6
 Specific Volume (cf/lb): 8.76
 UN No.: 2187

DOT Designation

Name: Carbon Dioxide, Refrigerated Liquid
 Label: Green, Nonflammable Gas

Hazard Classification: 2.2

PURITY SPECIFICATIONS

Purity : Carbon Dioxide ≥ 99.0%
 Odor: None

NO₂ ≤ 2.5ppm H₂S ≤ 1ppm
 SO₂ ≤ 5ppm
 CO ≤ 10ppm
 NO ≤ 2.5ppm
 NH₃ ≤ 2.5ppm

MSDS
 P-4573

CYLINDER SPECIFICATIONS

Equipment Recommendations

Ordering Number	Cylinder Size	Nominal Contents	Pressure (psig) @ 70°F	CGA Connection	Regulator
CD MLC180-350	180 L	400 lb	350	GAS-320 / LIQUID-622	WESM1-320-PG WESM1-320-P
CD MLC170-350	170 L	375 lb	350	GAS-320 / LIQUID-622	WESM1-320-PG WESM1-320-P

Color Code :

Shoulder Color: N /A

Body Color : N /A

Medical Applications

For close-to-physiologic atmospheres for the operation of artificial organs; in cryosurgery with unsufflators during laparoscopic surgery; and as a component in a mixture of oxygen or air as a respiratory stimulant to promote deep breathing.

Nitrogen N.F. Cryogenic Liquid

Colorless, odorless, nonflammable cryogenic liquid

Cryogenic Containers

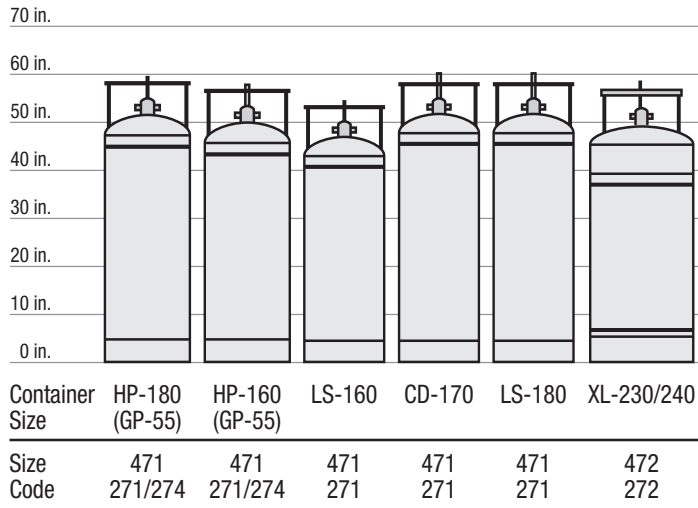

Major Hazards: High Pressure and Asphyxiation
 Toxicity: Nontoxic
 Fire Potential: Nonflammable
 Boiling Point (°F): -320.4
 Molecular Weight: 28.01
 Specific Gravity: 0.967
 Critical Temperature (°F): -237.8
 Critical Pressure (psia): 492.45
 Specific Volume (cf/lb): 13.8
 UN No.: 1977

DOT Designation

Name: Nitrogen, Refrigerated Liquid
 Label: Green, Nonflammable Gas

Hazard Classification: 2.2

PURITY SPECIFICATIONS

Purity : Nitrogen \geq 99.0%
 Odor: None

$CO \leq 10ppm$
 $O_2 \leq 1.0\%$

MSDS

P-4630

CYLINDER SPECIFICATIONS

Equipment Recommendations

Ordering Number	Cylinder Size	Nominal Contents	Pressure (psig) @ 70°F	CGA Connection	Regulator
NI MLC160-230	160 L	3690 cu ft	230	GAS-580 / LIQUID-295	WESM1-580-P WESM1-580-PG
NI MLC160-22	160 L	3690 cu ft	22	GAS-580 / LIQUID-295	N/A
NI MLC180-230	180 L	4110 cu ft	230	GAS-580 / LIQUID-295	WESM1-580-P WESM1-580-PG
NI MLC180-22	180 L	4110 cu ft	22	GAS-580 / LIQUID-295	N/A
NI MLC230-22	LC230	5023 cu ft	22	GAS-580 / LIQUID-295	N/A

Color Code :

Shoulder Color: N /A

Body Color : N /A

Medical Applications

As a component in many gas mixtures; as a displacement medium in pharmaceutical vials; as used in dermatology; as a propellant in pressurized aerosol type dispensers; as a coolant for carbon dioxide surgical lasers, and as a source of pneumatic pressure to power gas operated medical devices.

Medical Gas Mixtures



Praxair's Gas Mixtures

Praxair has been serving the healthcare industry for over 50 years. State of art cylinder filling facilities and thorough quality assurance programs ensure the preparation of high quality gases and high accuracy mixtures for research, diagnostics, calibration and inhalation therapy applications. The products classified by Food and Drug Administration (FDA-USA) as drug or devices are produced in accordance with current Good Manufacturing Practices (GMP). Praxair facilities are audited both internally and by the FDA.

Praxair's medical gas mixtures are labeled to clearly identify the gas components. The cylinder contents should be verified before use by carefully reading the label. Adapters must never be used to connect to a medical gas cylinder.

Mixture Product Summary

The following mixture product summary represents the most common medical mixtures for use within the healthcare industry. Praxair can accommodate most customer requests and specialized needs. Typical cylinder styles available are K and ME. Contact your Praxair representative for additional cylinder options available in your area.

Safe, Accurate, Consistent, Reliable... Every Time

Our sophisticated mixture software provides the very latest in mixture technology for our customers.

Blending Systems

Praxair prepares mixtures using high precision Gravimetric Balances or Volumetric Manifolds. All balances, gauges and process instruments undergo specific periodic maintenance and calibration in accordance with Praxair's proprietary process which conforms to FDA and current Good Manufacturing Practices.

Documentation: The following documents are available Upon Request:

- **Certificate of Compliance (COC):** A written guarantee that a product meets or exceeds the defined specifications.
- **Certificate of Analysis (COA):** A document that reports the actual analytical test results for pure products or mixtures. Either single cylinder or batch analysis certification is available, and must be specified at the time of request.

Grade Specifications and Tolerances:

- **Certified Standards:** These mixtures are prepared by either gravimetric or volumetric (partial pressure) methods. These standards are analyzed against Praxair Primary Laboratory Standards (PPLS).
- **Non-Certified Standards:** These mixtures are prepared by the same methods and the same care used for Certified Standard Grade. Analyses are not reported.
- **Primary Standard:** High accuracy mixtures prepared gravimetrically on an electronic high precision balance. These mixtures are analyzed against Praxair Primary Laboratory Standards (PPLS) and named to a gravimetrically generated concentration.

Mixture Component Concentration Range	Certified and Non Certified Standards Tolerances	Primary Standards Tolerances
100 ppm – 999 ppm	+/- 10% (relative)	+/- 5% (relative)
0.1% – 50%	+/- 5% (relative)	+/- 2% (relative)

Components for Medical Mixtures

- Nitrogen N.F.
- Carbon Dioxide U.S.P.
- Helium U.S.P.
- Nitrous Oxide U.S.P.
- Oxygen U.S.P.
- Acetylene
- Carbon Monoxide
- Hydrogen
- Methane
- Neon

Biological Atmospheres Anaerobic Incubation



Mixtures listed below are provided for Anaerobic incubator atmospheres:

- These mixtures typically represent a significant savings vs. the purchase of mixtures in small or disposable cylinders.
- Gas mixtures are available as certified standards
- Primary standard grade can be supplied on request
- Most common mixtures are listed
- Custom mixtures available upon request

5% Carbon Dioxide
5% Hydrogen
Balance Nitrogen

Part Number	Cyl	Grade	Nominal Contents	CGA	MSDS	Regulators
BI NICDHYC1-K	K	Certified	211 cu ft	350	P-18-0271	CON302-2331-350
BI NICDHYC1-T	T	Certified	281 cu ft	350	P-18-0271	CON302-2331-350

5% Carbon Dioxide
10% Hydrogen
Balance Nitrogen

Part Number	Cyl	Grade	Nominal Contents	CGA	MSDS	Regulators
BI NICDHYC2-K	K	Certified	211 cu ft	350	P-4857	CON302-2331-350
BI NICDHYC2-T	T	Certified	281 cu ft	350	P-4857	CON302-2331-350

5% Carbon Dioxide
Balance Nitrogen

Part Number	Cyl	Grade	Nominal Contents	CGA	MSDS	Regulators
BI NICD5C-K	K	Certified	211 cu ft	500	P-4858	WESM1-500-PGB
BI NICD5C-T	T	Certified	281 cu ft	500	P-4858	WESM1-500-PGB

10% Carbon Dioxide
10% Hydrogen
Balance Nitrogen

Part Number	Cyl	Grade	Nominal Contents	CGA	MSDS	Regulators
BI NICDHYC3-K	K	Certified	211 cu ft	350	P-18-0272	CON302-2331-350

10% Carbon Dioxide
5% Hydrogen
Balance Nitrogen

Part Number	Cyl	Grade	Nominal Contents	CGA	MSDS	Regulators
BI NICDHYC4-K	K	Certified	211 cu ft	350	P-18-0271	CON302-2331-350

Biological Atmospheres Aerobic Incubation



Mixtures listed below are provided for Aerobic incubator atmospheres:

- These mixtures typically represent a significant savings vs. the purchase of mixtures in small or disposable cylinders.
- Gas mixtures are available as certified standards
- Primary standard grade can be supplied on request
- Most common mixtures are listed
- Custom mixtures available upon request

2.5% Carbon Dioxide
21% Oxygen
Balance Nitrogen

Part Number	Cyl	Grade	Nominal Contents	CGA	MSDS	Regulators
BI NICDOXC3-K	K	Certified	228 cu ft	500	P-6250	WESM1-500-PGB

5% Carbon Dioxide
5% Oxygen
Balance Nitrogen

Part Number	Cyl	Grade	Nominal Contents	CGA	MSDS	Regulators
BI NICDOXC1-K	K	Certified	228 cu ft	500	P-6250	WESM1-500-PGB
BI NICDOXC1-T	T	Certified	304 cu ft	500	P-6250	WESM1-500-PGB

5% Carbon Dioxide
10% Oxygen
Balance Nitrogen

Part Number	Cyl	Grade	Nominal Contents	CGA	MSDS	Regulators
BI NICDOXC21-K	K	Certified	228 cu ft	500	P-6250	WESM1-500-PGB

5% Carbon Dioxide
21% Oxygen
Balance Nitrogen

Part Number	Cyl	Grade	Nominal Contents	CGA	MSDS	Regulators
BI NICDOXC4-K	K	Certified	228 cu ft	500	P-6250	WESM1-500-PGB

5% Carbon Dioxide
Balance Oxygen

Part Number	Cyl	Grade	Nominal Contents	CGA	MSDS	Regulators
BI OXCD5C-K	K	Certified	228 cu ft	500	P-4858	WESM1-500-PGB
BI OXCD5C-T	T	Certified	304 cu ft	500	P-4858	WESM1-500-PGB

10% Carbon Dioxide
21% Oxygen
Balance Nitrogen

Part Number	Cyl	Grade	Nominal Contents	CGA	MSDS	Regulators
BI NICDOXC24-K	K	Certified	228 cu ft	500	P-6250	WESM1-500-PGB

15% Carbon Dioxide
21% Oxygen
Balance Nitrogen

Part Number	Cyl	Grade	Nominal Contents	CGA	MSDS	Regulators
BI NICDOXC15-K	K	Certified	228 cu ft	500	P-6250	WESM1-500-PGB

Blood Gas Calibration



Typical uses for these mixtures include the calibration of clinical, transcutaneous and tonometry blood gas analyzers.

- Mixtures purchased in larger “K” and “T” size cylinders typically represent a significant savings vs. the purchase of mixtures in small or disposable cylinders.
- Blood Gas calibration mixtures will be supplied as certified standards unless otherwise specified.
- Primary standard grade can be supplied on request.
- Most common mixtures are listed.
- Custom mixtures available upon request.

3% Carbon Dioxide
4% Oxygen
Balance Nitrogen

Part Number	Cyl	Grade	Nominal Contents	CGA	MSDS	Regulators
BG NICDOXC12-K	K	Certified	214 cu ft	500	P-4858	WESM1-500-PGB

4% Carbon Dioxide
16% Oxygen
Balance Nitrogen

Part Number	Cyl	Grade	Nominal Contents	CGA	MSDS	Regulators
BG NICDOXC3-E	M-E	Certified	20 cu ft	973	P-4858	WESM1-973-PGB
BG NICDOXC3-K	K	Certified	214 cu ft	500	P-4858	WESM1-500-PGB
BG NICDOXP26-E	M-E	Primary	20 cu ft	973	P-4858	WESM1-973-PGB

5% Carbon Dioxide
5% Oxygen
Balance Nitrogen

Part Number	Cyl	Grade	Nominal Contents	CGA	MSDS	Regulators
BG NICDOXC23-K	K	Certified	214 cu ft	500	P-4858	WESM1-500-PGB
BG NICDOXP1-K	K	Primary	214 cu ft	500	P-4858	WESM1-500-PGB

5% Carbon Dioxide
10% Oxygen
Balance Nitrogen

Part Number	Cyl	Grade	Nominal Contents	CGA	MSDS	Regulators
BG NICDOXP3-K	K	Primary	214 cu ft	500	P-4858	WESM1-500-PGB

5% Carbon Dioxide
12% Oxygen
Balance Nitrogen

Part Number	Cyl	Grade	Nominal Contents	CGA	MSDS	Regulators
BG NICDOXC19-E	M-E	Certified	20 cu ft	973	P-4858	WESM1-973-PGB
BG NICDOXC4-K	K	Certified	214 cu ft	500	P-4858	WESM1-500-PGB

5% Carbon Dioxide
20% Oxygen
Balance Nitrogen

Part Number	Cyl	Grade	Nominal Contents	CGA	MSDS	Regulators
BG NICDOXC2-E	M-E	Certified	20 cu ft	973	P-4858	WESM1-973-PGB
BG NICDOXC2-K	K	Certified	214 cu ft	500	P-4858	WESM1-500-PGB
BG NICDOXP2-E	M-E	Primary	20 cu ft	973	P-4858	WESM1-973-PGB

5% Carbon Dioxide
Balance Nitrogen

Part Number	Cyl	Grade	Nominal Contents	CGA	MSDS	Regulators
BG NICD5C-E	M-E	Certified	20 cu ft	973	P-4858	WESM1-973-PGB
BG NICD5C-K	K	Certified	214 cu ft	500	P-4858	WESM1-500-PGB

5% Carbon Dioxide
15% Oxygen
Balance Nitrogen

Part Number	Cyl	Grade	Nominal Contents	CGA	MSDS	Regulators
BG NICDOXC43-E	ME	Certified	20 cu ft	973	P-4858	WESM1-973-PGB

10% Carbon Dioxide
21% Oxygen
Balance Nitrogen

Part Number	Cyl	Grade	Nominal Contents	CGA	MSDS	Regulators
BG NICDOXC10-E	M-E	Certified	20 cu ft	973	P-4858	WESM1-973-PGB

10% Carbon Dioxide
Balance Nitrogen

Part Number	Cyl	Grade	Nominal Contents	CGA	MSDS	Regulators
BG NICD10C-E	M-E	Certified	20 cu ft	973	P-4858	WESM1-973-PGB
BG NICD10C-K	K	Certified	214 cu ft	500	P-4858	WESM1-500-PGB
BG NICD10P-E	M-E	Primary	20 cu ft	973	P-4858	WESM1-973-PGB

12% Carbon Dioxide
Balance Nitrogen

Part Number	Cyl	Grade	Nominal Contents	CGA	MSDS	Regulators
BG NICD12C-E	M-E	Certified	20 cu ft	973	P-4858	WESM1-973-PGB

26% Oxygen
Balance Nitrogen

Part Number	Cyl	Grade	Nominal Contents	CGA	MSDS	Regulators
BG NIOX26C-E	M-E	Certified	20 cu ft	890	P-4858	WESM1-890-PGB
BG NIOX26C-K	K	Certified	214 cu ft	280	P-4858	WESM1-280-PGB

10% Carbon Dioxide
5% Oxygen
Balance Nitrogen

Part Number	Cyl	Grade	Nominal Contents	CGA	MSDS	Regulators
BG NICDOXC8-K	K	Certified	214 cu ft	500	P-4858	WESM1-500-PGB

9.5% Carbon Dioxide
14% Oxygen
Balance Nitrogen

Part Number	Cyl	Grade	Nominal Contents	CGA	MSDS	Regulators
BG NICDOXC69-E	M-E	Certified	20 cu ft	973	P-4858	WESM1-973-PGB

5% Carbon Dioxide
2.5% Oxygen
Balance Nitrogen

Part Number	Cyl	Grade	Nominal Contents	CGA	MSDS	Regulators
BG NICDOXP5-K	K	Primary	214 cu ft	500	P-4858	WESM1-500-PGB

Heliox



Heliox is the term used to describe mixtures of helium and oxygen. The mixtures listed are typically prescribed for patients with severe dyspnea or upper airway obstruction.

When combined with oxygen, helium reduces the density of the breathable mix. A 70/30 helium-oxygen mix is 2.3 times less dense than air and an 80/20 mixture is 3 times less. (See chart below)

Gas	Density (kg/m ³)	Viscosity (μP)
Air	1.20	183
100% Oxygen	1.33	204
Heliox 70/30	0.52	199
Heliox 80/20	0.40	198

Most frequently prescribed mixture concentrations are listed below. Custom mixtures available upon request.

20% Oxygen
Balance Helium

Part Number	Cyl	Grade	Nominal Contents	CGA	MSDS	Regulators
MM HEOX20LCQ-K	K	U.S.P.	255 cu ft	280	P-18-0010	Regulator included
MM HEOX20-G	G	U.S.P.	42 cu ft	280	P-18-0010	CON305-9391-280

30% Oxygen
Balance Helium

Part Number	Cyl	Grade	Nominal Contents	CGA	MSDS	Regulators
MM HEOX30-K	K	U.S.P.	255 cu ft	280	P-18-0014	CON305-9392-280

30% Oxygen
Balance Helium

Part Number	Cyl	Grade	Nominal Contents	CGA	MSDS	Regulators
MM HEOX30-AEGNG	AE	U.S.P.	25 cu ft	NR	P-18-0014	Regulator included

High-Pressure Cylinders

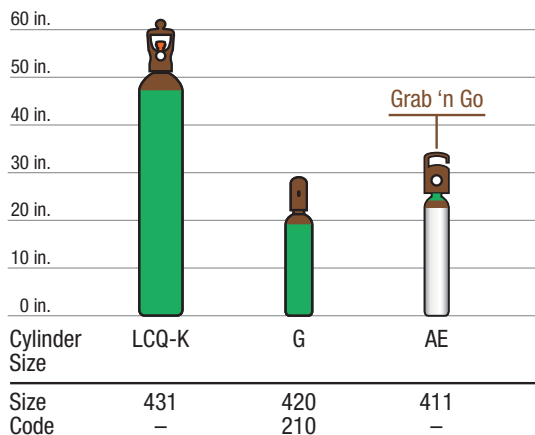

With Praxair, Getting Heliox to Your Patients is Easier Than Ever

Introducing the *Grab 'n Go*® Heliox System.

Praxair Healthcare Services raises the bar with the next generation advanced portable respiratory system for heliox, using a 70/30 mixture.

If you are using heliox to treat your patients, the new *Grab 'n Go* Heliox unit provides a highly portable means to respond. The dual-port design facilitates the flow of heliox to the mask and nebulizer. We've designed these features and more into a new durable, lightweight integrated unit inspired by our award-winning *Grab 'n Go* family of portable medical oxygen systems. Praxair ships more than one million *Grab 'n Go* advanced respiratory systems a year to healthcare facilities throughout the U.S. and Canada.

Lightweight integrated regulator, handle and cylinder

Integrated Lexan® protective shroud provides high impact strength for maximum protection and lighter weight. And it's rugged – the *Grab 'n Go* unit has passed the ASTM drop test for cylinders as specified in EN738-3. Get a better grip with the ergonomically designed molded handle that provides comfort and balance to make carrying easier for all hand sizes.

Single-knob operation

Patent pending single valve helps to eliminate confusion about turning the unit on and setting flow in an emergency.

Nebulizer-ready

With two delivery ports, one port to drive the nebulizer at a preset flow rate of 12 L/min and one to provide a controlled atmosphere rate range of 1 to 25 L/min.

Built-in contents gauge

With easy to read dial for accurate reading of remaining contents.

Integrated solid brass regulator

The regulator is permanently attached to the cylinder. Just return the empty *Grab 'n Go* system for another.

Built-in relief valve

An additional safety feature.

Aluminum E cylinder

For light weight and strength.

Color-coded full-shroud and cylinder

Distinctive colors make it even easier to select the correct unit, and helps eliminate confusion in an emergency.



The *Grab 'n Go* Heliox System from Praxair Healthcare Services – Your Patients Will Breathe Easier and So Will You.

Manufactured for Praxair by Western Medica, Westlake, OH 44145

30% Oxygen
Balance Helium

Part Number	Cyl	Grade	Nominal Contents	CGA	MSDS	Regulators
MM HEOX30-AEGNG	AE	U.S.P.	25 cu ft	NR	P-18-0014	Regulator included

Medical Laser



These mixtures are offered for use with surgical lasers:

- Gas mixtures are available as certified standards
- Non certified standards are also available.
- Most common mixtures are listed
- Custom mixtures available upon request
- Primary standard Grade can be supplied on request

4.5% Carbon Dioxide
13.5% Nitrogen
Balance Helium

Part Number	Cyl	Grade	Nominal Contents	CGA	MSDS	Regulators
ML HEC7-E	M-E	Certified	20 cu ft	973	P-4858	WESM1-973-PGB

5% Carbon Dioxide
14% Nitrogen
Balance Helium

Part Number	Cyl	Grade	Nominal Contents	CGA	MSDS	Regulators
ML HEC20-E	M-E	Certified	20 cu ft	973	P-4858	WESM1-973-PGB

7% Carbon Dioxide
14% Nitrogen
Balance Helium

Part Number	Cyl	Grade	Nominal Contents	CGA	MSDS	Regulators
ML HEC2-E	M-E	Certified	20 cu ft	973	P-4858	WESM1-973-PGB

Medical Gas Mixtures



These mixtures are offered for research diagnostics and inhalation therapy applications:

- Gas mixtures are available as certified standards
- Primary standard grade can be supplied on request
- Most common mixtures are listed
- Custom mixtures available upon request

5% Carbon Dioxide
Balance Oxygen

Part Number	Cyl	Grade	Nominal Contents	CGA	MSDS	Regulators
MM OXCD5-E	M-E	U.S.P.	23 cu ft	880	P-4858	WESM1-880-PGB
MM OXCD5-K	K	U.S.P.	220 cu ft	280	P-4858	WESM1-280-PGB

10% Carbon Dioxide
Balance Oxygen

Part Number	Cyl	Grade	Nominal Contents	CGA	MSDS	Regulators
MM OXCD10-K	K	U.S.P.	220 cu ft	500	P-4858	WESM1-500-PGB

Lung Diffusion



Typical uses for these mixtures include the calibration of pulmonary function testing equipment and inhalation for pulmonary function assessments:

- Lung Diffusion mixtures will be supplied as certified standards unless otherwise specified.
- Primary standard grade can be supplied on request.
- Most common mixtures are listed
- Custom mixtures available upon request

100ppm Carbon Monoxide
21% Oxygen
Balance Nitrogen

Part Number	Cyl	Grade	Nominal Contents	CGA	MSDS	Regulators
LD C017C-K	K	Certified	209 cu ft	500	P-4862	WESM1-500-PGB

0.3% Carbon Monoxide
0.3% Acetylene
0.3% Methane
21% Oxygen
Balance Nitrogen

Part Number	Cyl	Grade	Nominal Contents	CGA	MSDS	Regulators
LD AC2C-Q	Q	Certified	75 cu ft	500	P-4862	WESM1-500-PGB
LD AC2C-K	K	Certified	209 cu ft	500	P-4862	WESM1-500-PGB

0.3% Carbon Monoxide
0.3% Methane
21% Oxygen
Balance Nitrogen

Part Number	Cyl	Grade	Nominal Contents	CGA	MSDS	Regulators
LD ME1C-Q	Q	Certified	75 cu ft	500	P-4862	WESM1-500-PGB
LD ME1P-K	K	Primary	209 cu ft	500	P-4862	WESM1-500-PGB

0.3% Carbon Monoxide
0.5% Neon
21% Oxygen
Balance Nitrogen

Part Number	Cyl	Grade	Nominal Contents	CGA	MSDS	Regulators
LD NE1C-E	E	Certified	23 cu ft	973	P-4862	WESM1-973-PGB
LD NE1C-Q	Q	Certified	75 cu ft	500	P-4862	WESM1-500-PGB
LD NE1C-K	K	Certified	209 cu ft	500	P-4862	WESM1-500-PGB

0.3% Carbon Monoxide
10% Helium
21% Oxygen
Balance Nitrogen

Part Number	Cyl	Grade	Nominal Contents	CGA	MSDS	Regulators
LD C01C-E	M-E	Certified	20 cu ft	973	P-4862	WESM1-973-PGB
LD C01C-K	K	Certified	209 cu ft	500	P-4862	WESM1-500-PGB
LD C01C-Q	Q	Certified	75 cu ft	500	P-4862	WESM1-500-PGB

Bulk Liquid Oxygen U.S.P. Storage Systems



Bulk Liquid Oxygen U.S.P.

Praxair offers storage facilities and reserve supplies for its *Medipure*[®] brand cryogenic liquid Oxygen U.S.P. to meet current NFPA standards. Bulk storage units and either liquid or high-pressure cylinder reserve supplies are sized specifically to your facility based on usage patterns and geography. Control equipment is maintenance-friendly and designed to provide interruption-free service.

In addition to providing equipment to meet NFPA requirements, Praxair's *Tracker*[™] remote inventory monitoring system can provide an around-the-clock link to our North American Logistics Center in Tonawanda, N.Y. *Tracker*[™] continuously monitors tank levels, automatically places your order for delivery, provides physical plant operations remote data access and can be integrated to your central monitoring system.

Stringent production, transport and handling procedures help ensure that Praxair's liquid Oxygen U.S.P. meets or exceeds standards of the United States Pharmacopoeia, as delivered to the storage tank at the hospital.

The broad acceptance of bulk liquid storage systems stems from their reliability and compact design, making them particularly practical where hospital ground space is limited. Praxair's specially designed cryogenic storage tanks feature double-walled construction with efficient insulation to minimize evaporation

losses. When gaseous Oxygen U.S.P. is needed, the liquid Oxygen U.S.P. automatically converts to gaseous form as it flows through the vaporizer – an ambient air heat exchanger – before it enters the hospital's distribution pipeline. An integrated backup supply system automatically feeds gaseous Oxygen U.S.P. to the pipeline if the regular Oxygen U.S.P. supply is interrupted for any reason.

Bulk liquid Oxygen U.S.P. storage systems are available in a variety of sizes. Before Praxair recommends the most appropriate size for any given hospital, we carefully weigh a number of critical factors including: the bed size of the hospital, the hospital's geographic location, the existing rate and pattern of Oxygen U.S.P. use, available installation space and accessibility of the site for transport deliveries.

Praxair offers compact, custom fit, cost effective solutions for your bulk liquid Oxygen U.S.P. requirements:

- Automatic switching between vaporizer sections significantly reduces icing and puts less stress on the system
- Remote monitoring through Praxair's Electronic Link *Tracker*[™] System continuously monitors your tank level and automatically places your order for delivery, for uninterrupted supply
- Group Purchasing Organization (GPO) benefits available to members
- Proactive support with FDA regulatory compliance

Basic Properties of Liquid Oxygen U.S.P.:

Density: 71.27 lb. per cu. ft. at boiling point
 Heat of Vaporization: 91.7 BTU per lb.
 Boiling Point: -297.3°F at 1 atmosphere
 Freezing Point: -361.8°F at 1 atmosphere

Purity and Moisture Content of Bulk Liquid Oxygen U.S.P.:

Minimum Purity: 99.0%
 Maximum Moisture Content: 6 ppm
 Approximate Dewpoint at Maximum Moisture Content: -84°F

Tank Selection Table

- Based on primary tank, reserve tank, vaporizer, and medical cabinet.
- Cement pad dimensions are for zone 2 areas only. For other seismic zones, consult your Praxair representative.
- Configuration will vary by individual site and distance from plant
- Standard spill pad - 12' X 10'.
- Praxair recommends a reserve tank with 24-hour capacity.

Primary Tank Size (gallons)	Reserve Tank Size (gallons)	Cement Pad Size (length x width)
1500	120	19' X 20'
3000	500	25' X 26'
6000	1500	25' X 26'
9000	1500	27' X 27'
11000	3000	27' X 27'
13000	3000	27' X 27'

Your Electronic Link

Tracker provides you with an around-the-clock link with Praxair. By transmitting information electronically to our North American Logistics Center in Tonawanda, N.Y., through a remote telemetry unit, the *Tracker™* system:

- Continuously monitors your tank level
- Automatically places your order for delivery
- Provides you with access to your product levels
- Stores tank-level readings in 10-minute intervals for 10 days
- Offers data in ASCII format
- Provides real-time data for inventory management
- Can be integrated with your plant computer system

How It Works

The heart of our *Tracker™* system is an advanced microprocessor installed on each of your gas supply tanks. With this and a simple telephone line, we can access all of the vital data necessary to keep your tank operation up and running.

Relying on this information, the *Tracker™* determines when your reorder point is reached, and an order is automatically generated for delivery, so you always have the gases you need.

The *Tracker™* system also includes a Remote Access Program (RAP), a cost-free option that enables you to have direct access to information from your *Tracker™* units.

With your computer and modem, you not only can access your current product level, RAP also lets them display usage information in either a table or a line graph. In fact, you can review the last 10 days of tank-level readings. RAP, which is available upon request, includes all the software and instructions you'll need for easy set-up.

Uninterrupted Supply

Up-to-the minute tank-level readings... automatic reordering... reliable gas supply... Three key reasons for relying on *Tracker™* to manage your gas inventory. Coupled with Praxair Supply Management, *Tracker™* provides the answer to 100% uninterrupted product supply. For more information about *Tracker™* and other Praxair programs and services, call Praxair.

Hyperbaric Oxygen Therapy

From Praxair Healthcare Services, Medical Bulk Oxygen U.S.P. Systems for Hyperbaric Oxygen Therapy:

- Are you considering offering Hyperbaric Oxygen Therapy?
- If you want hyperbaric oxygen capabilities, we can refer you to one of our select, hyperbaric service partners.
- Before you install a chamber, we can evaluate the unit's impact on your current bulk oxygen system and recommend upgrade solutions to handle the volume increase in gas usage.
- When usage of a chamber will require a dedicated bulk oxygen system, Praxair can install a new oxygen system in your facility.

General Considerations for Hyperbaric Oxygen Supply

Compliance

A hyperbaric oxygen facility consists of a pressurized chamber and related equipment used for medical procedures performed at pressures above normal atmospheric pressure.

Hyperbaric (HBO) facilities must comply with standards published by the National Fire Protection Association in their pamphlets or standards NFPA-50, NFPA-99, NFPA-55, NFPA-101 as well as Guidelines published by the Compressed Gas Association in CGA M-1. Review the issues related to HBO compliance before installing or making changes to a facility.

Typical Gas-Source Supply Scenarios

Scenario #1

Installation of a dedicated oxygen system to supply the Hyperbaric Facility:

No matter what type of facility you operate, proposed standards require an adequately sized reserve supply of oxygen IN ADDITION to the main tank. NFPA or CGA recommends a reserve supply whether or not the facility is located in a hospital.

Scenario #2

Installation of a Hyperbaric Facility tied into an existing oxygen supply system IF SUPPLIED AT THE SAME PRESSURE AS THE EXISTING SYSTEM, both the main oxygen source of supply and the reserve must be evaluated to ensure they are properly sized to supply the additional volume to the facility, without jeopardizing the existing pressure and flow requirements of oxygen to the patients, and the minimum 24hr reserve supply required by NFPA. IF SUPPLIED AT A DIFFERENT PRESSURE (usually higher), then

1. The existing source of supply and reserve must be adequately sized to support the additional volumes (as above), and
2. A separate auxiliary dual-line regulator module/control cabinet with individual alarms must be located downstream of the reserve supply, or
3. A dedicated source of supply and reserve must be installed.

Other Typical Gas Related Issues to be aware of:

In the NFPA's Standards, particular reference to the following issues should be considered. NFPA-99 Chapter 20 and NFPA-101:

- Shut-off valves must be installed at the point of entry to the chamber rooms.
- Storage and handling must meet the applicable NFPA-99 Chapter 5 requirements.
- The bulk installation must meet NFPA-50 requirements.



NFPA-50, NFPA-55, requirements:

- Must conform to installation siting requirements
- All equipment must be designed and cleaned for oxygen service
- Piping must be tested

CGA M-1 Requirements:

- Reserve supply for all installations
- Alarms as specified by NFPA-99

Planning

If you are planning to install or modify a hyperbaric oxygen facility, call your Praxair representative early in the process. Praxair offers consultation, site-survey and system assessments to help round-out your planning to include all medical gases and related equipment.

The information contained herein is not intended to summarize all of the risk associated with the installation of a hyperbaric oxygen facility nor does it identify the most significant or material risks associated with such installation.

Liquid Helium for MRI



MRI Helium Transfilling: The Cost-Effective Choice

Why use Original Equipment Manufacturer (OEM) helium transfilling services for your Magnetic Resonance Imaging (MRI) needs when you can save up to 30 percent with the Praxair Independent Service Organization (ISO) network?

Experienced, Independent Suppliers

Praxair created the ISO network to provide the same level of service you are receiving now, without the high price of an OEM. Each Praxair ISO network member is an experienced, independent supplier. One phone call to Praxair is all it takes. We'll schedule your cryogen deliveries and transfills anywhere in the U.S, whether you have one or multiple locations. The service is available 24 hours a day, seven days a week – all backed by Praxair's years of experience supplying hospitals, MRI operators and others in the medical community.

Supply Reliability

Since 1917, Praxair has been the world's top helium producer, as well as a leader in distribution and technology. Praxair customers rest easy because our long-term crude helium supply is backed by stored reserves, ensuring both their short- and long-term supply. Behind our supply capability are more than thirty major

distribution centers strategically located to provide helium worldwide, around the clock, and our processes for both helium production and distribution have been ISO 9002 certified since 1992.

Call Today

In short, you have one-stop shopping for all your helium supply and transfilling needs. So, why rely on expensive MRI transfilling services when you can save up to 30% with the Praxair ISO network? Call Praxair today at 1-800-328-1654 and see the difference we can make to your bottom line.

CYLINDER SPECIFICATIONS

Ordering Number	Cylinder Size	Nominal Contents	Pressure (psig) @ 70°F	CGA Connection
HE LT30	CMSH-30 L	30 L	1	Coupling for 3/8" or 1/2" transfer tube
HE LT60	CMSH-60L	60 L	1	Coupling for 3/8" or 1/2" transfer tube
HE LT100	CMSH-100 L	100 L	1	Coupling for 3/8" or 1/2" transfer tube
HE LT250	CMSH-250 L	250 L	1	Coupling for 5/8" or 3/4" transfer tube
HE LT350	CMSH-350 L	350 L	1	Coupling for 5/8" or 3/4" transfer tube
HE LT500	CMSH-500 L	500 L	1	Coupling for 5/8" or 3/4" transfer tube
HE 6.0MR-VT	T	291 cu.ft.	2000	580

Dry Ice

Dry Ice for specimen storage and shipping

From pharmaceutical lab applications to DNA research and gene splicing, Praxair's *Ultralce*® premium dry ice plays an important role in preserving biological samples. That's why Praxair, the world's largest carbon dioxide supplier and a leading supplier of medical gases and related technologies, is developing cost-saving applications to meet your biotechnology requirements.

Blocks are still the most common form of dry ice. But Praxair's dry ice also takes the shape of snow and nuggets, sheets, slices and rice pellets. Praxair's dry ice blocks, starting at 50 pounds, are the most economical form of cold, solid carbon dioxide. They're easily shipped in containers, lose little through sublimation, and they can be crushed into chunks or sliced into sheets and used for packing. Dry ice snow is perfect for storing biological samples, while sheets and slices can also meet this need. Praxair's nuggets (3/8", 1/2" or 3/4" in diameter by 1/4" to 1/2" long) and rice pellets (2.9 mm) offer two other safe, convenient shapes and sizes, and many other benefits, including:

- Easy handling and distribution
- Quick, economical refrigeration
- Precise temperature control
- Easy, accurate portion control
- Uniform cold distribution for fast, thorough cooling
- Come ready to use, eliminating the labor and waste of handling, cutting, breaking or crushing conventional blocks
- Can be scooped and poured between and around products to fill any size or shape cavity, or applied directly to the product being cooled

For Safe Handling and Storage of Dry Ice, please refer to our "Safety & Reference Data" section.



Supply reliability and more:

Praxair Healthcare Services offers the benefits of:

- Reliability – from choosing the world's largest carbon dioxide supplier
- The industry's largest production and distribution network
- Over 70 years of hands-on experience developing dry ice applications and related technology
- Ongoing support from the industry's most experienced technicians and engineers

Praxair Healthcare Services also offers a full line of dry ice accessories, from storage chests and handling devices to temperature data loggers and dry ice makers. See why labs and institutions just like yours have relied on our leadership for over 70 years. Call your representative and let us show you how we can deliver the right solutions for your biotechnology application.

Ordering Information:

Part Number	Description
CD SLICED	Sliced, cut to size, 25 lb cut into two 12.5 lb slices (approx 12" x 12" x 3"). 50 lb cut into four slices (approx 12" x 12" x 3"), shipped in insulated containers
CD BLOCK	Blocks cut to size, 25 lb cut into one block (12" x 12" x 6"). 50 lb cut into one block (12" x 12" x 12"), shipped in insulated containers.
CD RICE	High density 1/8" diameter. Dry ice pellets, nugget form 1/4", 5/8", 3/4" in diameter by 1/4" to 1.5" long, shipped in insulated containers.

Accessories for High Pressure Cylinders



Cylinder Carts

- Environmentally safe color coatings
- Lightweight, electrically welded
- Constructed of high tensile steel
- Quiet, easy rolling wheels
- Single and dual carts for transport

Part Number	Description	Weight (lbs)	Height (in)	Width (in)	Depth (in)
ANT6110	Large cylinder cart for 1 T/K cylinder	23	46	15	N/A
ANT6114	Large cylinder cart for 1 T/K cylinder with two casters	30	46	15	N/A
ANT6214	Large cylinder cart for 2 T/K cylinders with two casters	30	46	15	N/A
ANT6105	Small cylinder cart for 1 E/D cylinder	8	41	12	N/A
ANT6205	Small cylinder cart for 2 E/D cylinders	8	41	12	N/A
ANT6105MRI	Small cylinder cart, non-magnetic, for 1 E cylinder	8	41	12	N/A
ANT6205MRI	MRI small cylinder cart, non-magnetic, for 2E cylinders	8	41	14	N/A
ANT6114-R	Large cylinder cart for 2 T/K cynders with 2 casters, N/R	30	46	15	N/A



Cylinder Transport Carts

- Transport carts designed for E/D size cylinders
- Heavy gauge, angle iron steel frame
- Large, heavy duty, lockable casters
- Removable handle for pushing or pulling

Part Number	Description	Weight (lbs)	Height (in)	Width (in)	Depth (in)
ANT6246	Heavy duty, capacity 24 E/D cylinders	75	45	21	31
ANT6244	Medium duty, capacity 24 E/D cylinders	50	42	20	30
ANT6124	Medium duty, capacity 12 E/D cylinders	44	42	22	20



Cylinder Bases

- Bases for K, M, E,D size cylinders
- Durable, lightweight design
- Can be bolted to the floor
- Sold individually

Part Number	Description
HUD4040	Small cylinder base for E/D cylinders
HUD4046	Medium cylinder base for M cylinders
HUD4045	Large cylinder base for K/H cylinders



Cylinder Wall and Bench Brackets

- Double reinforced steel
- Available with nylon belt or safety chain
- For wall or bench mounting

Part Number	Description	Weight (lbs)	Height (in)	Width (in)	Depth (in)
ANTWB-100	Wall bracket holds 7"-9" diameter cylinder	3	N/A	11	6
ANTWB-200	Wall bracket holds two 7"-9" diameter cylinders	5	N/A	22	7
ANTWB-100-15	Wall bracket holds 10"-16" diameter cylinder	4	N/A	16	12
ANTWB-200-15	Wall bracket holds two 10"-16" diameter cylinders	6	N/A	31	12
ANTBM-100	Bench mount holds 7"-9" diameter cylinder	4	N/A	11	8
ANTWB-100C	Wall bracket holds 7"-9" diameter cylinder	3	N/A	11	6



Cylinder Wrenches

- Cylinder wrenches for small E/D size cylinders
- Available in either metal or plastic
- Sold individually

Part Number	Description
WESMCW-2B	Metal wrench
WESMCW-2BC	Metal wrench w/security chain
WESMCW-3P	Plastic wrench
WESMCW-3PC	Plastic wrench w/security chain



Cylinder Stands

- Single and multiple cylinder stands
- For single and multiple cylinder storage

Part Number	Description	Weight (lbs)	Height (in)	Width (in)	Depth (in)
ANT6120	Holds 12 E/D size cylinders	18	18	18	12
ANT610F-E	Holds 1 T/K cylinder	14	12	18	18



Cylinder Yoke Washers

- Yoke washers for E/D size cylinders

Part Number	Description
WES2544-2	Yoke washer for E/D size cylinders

Accessories for Cryogenic Containers



Midarm shown

Cryo Gloves

- Safety gloves for cryogenic use
- Protects hands when handling cryogenic liquids
- Elbow length available for extra protection

Part Number	Description
MVE9717119	Cryoglove, midarm, medium
MVE9717129	Cryoglove, midarm, large
MVE9717139	Cryoglove, midarm, extra large
MVE9717149	Cryoglove, elbow length, medium
MVE9717159	Cryoglove, elbow length, large
MVE9717169	Cryoglove, elbow length, extra large
MVE10464394	Cryo Apron



Phase Separators

- For dispensing liquid with less splashing
- For use in non-pressurized environments

Part Number	Description
MVE10615869	Phase separator, 1-5/8" diameter, 4" long
MVE10615877	Phase separator, 1-5/16" diameter, 3" long
MVE10615885	Phase separator, 1-11/16" diameter, 1-1/2" long



Faceshields, Safety Glasses:

- For cryogenic use
- Provides extra wrap around
- Windows form a shield from dust and debris

Part Number	Description
NREF300	Faceshield, lightweight
NREF400	Headgear with 4" crown ratchet
CRESS110	Clear safety glasses



Liquid Transfer Hoses

- Close pitch stainless steel corrugated bore
- Highly flexible for cryogenic applications
- ISO 10380 certified for bend cycle life
- 1160 psi working pressure
- 6104 psi burst pressure
- Custom lengths available on request

Part Number	Description
PRSUF21-IN3	Inert service, 3ft, CGA295 each end
PRSUF21-IN6	Inert service, 6ft, CGA295 each end
PRSUF21-OX3	Oxygen service, 3ft, CGA440 each end
PRSUF21-OX6	Oxygen service, 6ft, CGA440 each end



Cool Reach and Dippers:

- Designed for easy retrieval of samples
- Dippers assist in transfer of liquid nitrogen

Part Number	Description
MVE13051579	Cryoclaw
MVE9711589	Dipper, 18" handle, for 10 liter dewar
MVE9711619	Dipper, 19" handle, for 20 liter dewar
MVE9711679	Swivel dipper
MVE10668101	Lab10 manual discharge device
MVE13464867	Lab 20 manual discharge device
MVE10668004	Lab 30 manual discharge device

Hose Assemblies



- Designed for gas distribution in centralized areas of hospitals, dental clinics and veterinary facilities
- Available in many different styles and combinations made to customer specifications
- All hoses are color coded and conductive
- All hose assemblies are 100% tested under simulated field conditions
- DISS Female connection available with a hand tight style color coded knurled nut for easy tightening
- DISS Male connection available with check valve
- Oxygen, carbon dioxide, medical air and nitrous oxide assembled to a working pressure of 50 psig; nitrogen to 180 psig
- All hoses are 1/4 inch ID, except vacuum which is 5/16 inch ID

Connection Style, Quick Connector and DISS Hose Fittings

DISS Handtight Nut



Oxequip-style Adapter



Ohmeda-style Adapter



Puritan-style Adapter



Chemetron-style Adapter



Gas	Part Number	Length (ft)	Description
Carbon Dioxide	AMVHS01UCC4	50	Bulk Hose
Medical Air	AMVHS06UADFPFC4	6	DISS F by Puritan F
	AMVHS06UADFCFC4	6	DISS F by Chemetron F
	AMVHS06UADFOFC4	6	DISS F by Ohmeda F
	AMVHS10UADFCFC4	10	DISS F by Chemetron F
	AMVHS10UADHDHC4	10	DISS F Handtight by DISS F Handtight
	AMVHS10UADFCMC4	10	DISS F by Chemetron M
	AMVHS10UADFOMC4	10	DISS F by Ohmeda M
	AMVHS01UAC4	300	Bulk Hose
Nitrogen	AMVHS06UNDFSFC4	6	DISS F by Schrader F
	AMVHS10UNDFSFC4	10	DISS F by Schrader F
	AMVHS10UNSFDMC4	10	DISS M by Schrader F
	AMVHS10UNDFM4C4	10	DISS F by 1/4 inch NPT
	AMVHS01UNC4	300	Bulk Hose

Nitrous Oxide, Oxygen, Vacuum and WAGD continued on next page

Gas	Part Number	Length (ft)	Description
Nitrous Oxide	AMVHS03U2DFDFC4	3	DISS F by DISS F
	AMVHS04U2DFDFC4	4	DISS F by DISS F
	AMVHS06U2DFCFC4	6	DISS F by Chemetron F
	AMVHS06U2DFOFC4	6	DISS F by Ohmeda F
	AMVHS10U2DFDFC4	10	DISS F by DISS F
	AMVHS10U2DFOFC4	10	DISS F by Ohmeda F
	AMVHS10U2DFOMC4	10	DISS F by Ohmeda M
	AMVHS10U2DFSMC4	10	DISS F by Schrader M
	AMVHS01U2C4	300	Bulk Hose
Oxygen	AMVHS03U0DFDFC4	3	DISS F by DISS F
	AMVHS04U0DFDFC4	4	DISS F by DISS F
	AMVHS06U0DFOFC4	6	DISS F by Ohmeda F
	AMVHS06U0DFCFC4	6	DISS F by Chemetron F
	AMVHS06U0DFPFC4	6	DISS F by Puritan F
	AMVHS10U0DFDFC4	10	DISS F by DISS F
	AMVHS10U0DFDMC4	10	DISS F by DISS M
	AMVHS10U0DFDHC4	10	DISS F by DISS F, handtight nut and nipple
	AMVHS10U0DFCFC4	10	DISS F by Chemetron F
	AMVHS10U0DFOMC4	10	DISS F by Ohmeda M
	AMVHS10U0DFPFC4	10	DISS F by Puritan F
	AMVHS10U0DFOFC4	300	DISS F by Ohmeda F
	AMVHS01UOC4	50	Bulk Hose
	Vacuum	AMVHS06UVDFOFC5	6
AMVHS06UVDFCFC5		6	DISS F by Chemetron F
AMVHS10UVDFDFC5		10	DISS F by DISS F
AMVHS10UVDFOFC5		10	DISS F by Ohmeda F
AMVHS10UVDMCMC5		10	DISS M by Chemetron M
AMVHS01UVC5		250	Bulk Hose
WAGD	AMVHS06UWDFOFC4	6	DISS F by Ohmeda F
	AMVHS10UWDFOFC4	10	DISS F by Ohmeda F
	AMVHS01UWC4	300	Bulk Hose

Hose assemblies manufactured by AMVEX Corporation. Praxair features AMVEX Corporation products. AMVEX is a manufacturer of medical products serving the healthcare industry.



Fully Automatic Manifold



- High flow rate manifolds built in accordance with National Fire Protection Association and CGA Standards
- Cleaned, tested, prepared for the indicated gas service, and constructed in accordance with NFPA 99 and CGA
- Dual Line-Pressure Regulators incorporated into manifold design
- CGA connections with integral check valves at each header station
- Stainless steel flexible pigtails are provided for each gas connection, except for oxygen applications. Copper pigtails are provided for oxygen applications.
- Input power 120VAC, 50 to 60 Hz
- Built for expansion by adding header extensions

Manifold Configurations

Gas Service	Part Number	Cyl Conn	Flow Rate		Configuration	Mounting
			SCFH	M3/Hr		
Carbon Dioxide	TRTCU12CD1W04B	4	500	14	Std 10" OC	Wall
	TRTCU12CD1W06B	6	500	14	Std 10" OC	Wall
Medical Air	TRTCU12AI1L04B	4	2500	17	Std 10" OC	Wall
	TRTCU12AI1L06B	6	2500	17	Std 10" OC	Wall
	TRTCU12AI1L08B	8	2500	17	Std 10" OC	Wall
	TRTCU12AI1L10B	10	2500	17	Std 10" OC	Wall
Nitrogen	TRTCU12NT3H04B	4	3000	86	Std 10" OC	Wall
	TRTCU12NT3H06B	6	3000	86	Std 10" OC	Wall
	TRTCU12NT3H08B	8	3000	86	Std 10" OC	Wall
	TRTCU12NT3H10B	10	3000	86	Std 10" OC	Wall
Nitrous Oxide	TRTCU12NO1W04B	4	500	14	Std 10" OC	Wall
	TRTCU12NO1W06B	6	500	14	Std 10" OC	Wall
	TRTCU12NO1W08B	8	500	14	Std 10" OC	Wall
	TRTCU12NO1W10B	10	500	14	Std 10" OC	Wall
Oxygen	TRTCU12OX1L04B	4	2500	71	Std 10" OC	Wall
	TRTCU12OX1L06B	6	2500	71	Std 10" OC	Wall
	TRTCU12OX1L08B	8	2500	71	Std 10" OC	Wall
	TRTCU12OX1L010B	10	2500	71	Std 10" OC	Wall

Praxair features products manufactured by Tri-Tech Medical Inc.



**Tri-Tech
Medical Inc.**

Cylinder Storage Cabinets

FACT: When storing 'ME' or 'K' sized cylinders (300-3,000 cu ft), your facility must comply with NFPA 99 *Standards for Health Care Facilities*.

Section 9.4.2 of the Standards requires either 20ft of separation from combustible material, 5ft of separation with fire sprinklers or a lockable cabinet with a minimum ½ hr. fire rating. During recent inspections, The Joint Commission has made the storage of medical gases an area of its focus.

SOLUTION: Storage cabinets from Praxair make compliance easy. To help comply with NFPA99, to maximize the utilization of available space at nursing stations and to minimize the costs of remedial construction, hospitals and other healthcare facilities often choose fire-lined cylinder storage cabinets from Praxair.

These cabinets, insulated with 5/8" gypsum, are available for safe and convenient storage of medical gas cylinders in either an upright or horizontal position. They are designed to accept the popular Praxair Grab 'n Go cylinders, small cylinders with post-type valves, and large 'K', 'H' and 'T' size cylinders.



Vertical Storage



Horizontal Storage

5/8"
Gypsum
Lining
18 GA Steel

Three reasons to call Praxair today:

1. Cylinder storage cabinets designed to help meet current NFPA99 standards
2. Your Praxair representative is available to provide free consultation to help with compliance issues
3. Product availability

Vertical Storage Cabinets:

Part Number	Description	Weight (lbs)	Height (in)	Width (in)	Depth (in)
SRLMG109FL	Manual door style cabinet for 9-12 ME, MD, Grab'nGo, cylinders	199	44	23	18
SRLMG309FL	Self closing door style cabinet for 9-12 ME, MD, Grab'nGo, cylinders	209	46	23	18
SRLMG121FL	Manual door style cabinet for 21-24 ME, MD, Grab'nGo, cylinders	308	44	43	18
SRLMG321FL	Self closing door style cabinet for 21-24 ME, MD, Grab'nGo, cylinders	323	46	43	18
SRLMG106HFL	Manual door style cabinet for 6-9 S, K, T cylinders	436	65	31	31
SRLMG306HFL	Self closing door style cabinet for 6-9 S, K, T cylinders	458	67	31	31
SRLMG109HFL	Manual door style cabinet for 9-12 S, K, T cylinders	520	65	43	31
SRLMG309HFL	Self closing door style cabinet for 9-12 S, K, T cylinders	550	67	43	31

Horizontal Storage Cabinets:

Part Number	Description	Weight (lbs)	Height (in)	Width (in)	Depth (in)
ELSPA8FR1	Manual door style cabinet for 8 ME, MD, Grab'nGo cylinders	432	23	34	40
ELSPA8FR1S	Self closing door style cabinet for 8 ME, MD, Grab'nGo cylinders	458	25	34	40
ELSPA12FR1	Manual door style cabinet for 12 ME, MD, Grab'nGo cylinders	541	32	34	40
ELSPA12FR1S	Self closing door style cabinet for 12 ME, MD, Grab'nGo cylinders	567	34	34	40
ELSPA16FR1	Manual door style cabinet for 16 ME, MD, Grab'nGo cylinders	649	41	34	40
ELSPA16FR1S	Self closing door style cabinet for 16 ME, MD, Grab'nGo cylinders	675	43	34	40
ELSPA20FR1	Manual door style cabinet for 20 ME, MD, Grab'nGo cylinders	762	50	34	40
ELSPA20FR1S	Self closing door style cabinet for 20 ME, MD, Grab'nGo cylinders	788	52	34	40

Optional (specify when ordering):

Part Number	Description
ELSCA18-SG	Caster assembly, 2 rigid, 2 swivel, locking casters, 30 lbs.

Regulators for Oxygen Therapy: Adjustable Regulators with Flow Gauge



- Single-stage adjustable flow range
- Durable neoprene diaphragm
- Internal reseating relief valve protects against over pressurization
- UL listed
- Maximum inlet pressure 3000 psig (20700 kPa)
- Sintered filter for additional safety and to extend regulator life
- 2” diameter gauges
- Standard DISS 1240 outlet connection and plastic swivel hose barb
- 6 year warranty

Gas	Part Number	Flow Range	Connector Type
Oxygen	WESM1-540-15FG	2-15 LPM	CGA 540 Nut and Nipple
	WESM1-540-8FG	1-8 LPM	CGA 540 Nut and Nipple
	WESM1-870-15FG	2-15 LPM	CGA 870 Yoke
	WESM1-870-8FG	1-8 LPM	CGA 870 Yoke

Praxair is proud to feature Western Medica branded products. For over 40 years, Western has been developing and supplying equipment for the control, storage, and transmission of high pressure gases to various markets. Western products are designed and manufactured to provide unparalleled technical accuracy and performance for the most demanding applications.



Regulators for Medical Gases: Preset Regulators with Pressure Gauge



- Single-stage 50 psig (345 kPa) preset delivery pressure
- 1650 SCFH (46 m³) maximum flow at 2000 psig (13800 kPa)
- Internal reseating relief valve protects against over pressurization
- UL listed
- Maximum inlet pressure 3000 psig (20700 kPa)
- Sintered filter for additional safety and to extend regulator life
- 2" diameter gauges
- Standard DISS 1240 outlet connection and plastic swivel hose barb
- 6 year warranty

Gas	Part Number	Delivery Pressure	Connector Type
Carbon Dioxide	WESM1-320-P	50 psig	CGA 320 Nut and Nipple
Medical Air	WESM1-346-P	50 psig	CGA 346 Nut and Nipple
Nitrous Oxide	WESM1-326-P	50 psig	CGA 326 Nut and Nipple
Oxygen	WESM1-540-P	50 psig	CGA 540 Nut and Nipple
Helium	WESM1-580A-P	50 psig	CGA 580 Nut and Nipple

Praxair is proud to feature Western Medica branded products. For over 40 years, Western has been developing and supplying equipment for the control, storage, and transmission of high pressure gases to various markets. Western products are designed and manufactured to provide unparalleled technical accuracy and performance for the most demanding applications.



Regulators for Medical Gases: Adjustable Regulators with Pressure Gauge



- Single-stage adjustable delivery pressure to 100 psig (690 kPa)
- 1700 SCFH (47 m³) maximum flow at 2000 psig (13800 kPa)
- Internal reseating relief valve protects against over pressurization
- UL listed
- Maximum inlet pressure 3000 psig (20700 kPa)
- Sintered filter for additional safety and to extend regulator life
- 2" diameter gauges
- Standard DISS 1240 outlet connection and plastic swivel hose barb
- 6 year warranty

Gas	Part Number	Delivery Range	Connector Type
Carbon Dioxide	WESM1-320-PG	0-100 psig	CGA 320 Nut and Nipple
	WESM1-940-PG	0-100 psig	CGA 940 Yoke
Helium	WESM1-580A-PG	0-100 psig	CGA 580 Nut and Nipple
	WESM1-930-PG	0-100 psig	CGA 930 Yoke
Medical Air	WESM1-346-PG	0-100 psig	CGA 346 Nut and Nipple
	WESM1-950-PG	0-100 psig	CGA 950 Yoke
Nitrogen	WESM1-580-PG	0-100 psig	CGA 580 Nut and Nipple
	WESMSH180-580	0-180 psig	CGA 580 Nut and Nipple
	WESM1-960-PG	0-100 psig	CGA 960 Yoke
Nitrous Oxide	WESM1-326-PG	0-100 psig	CGA 326 Nut and Nipple
	WESM1-910-PG	0-100 psig	CGA 910 Yoke
Oxygen	WESM1-540-PG	0-100 psig	CGA 540 Nut and Nipple
	WESM1-870-PG	0-100 psig	CGA 870 Yoke

Praxair is proud to feature Western Medica branded products. For over 40 years, Western has been developing and supplying equipment for the control, storage, and transmission of high pressure gases to various markets. Western products are designed and manufactured to provide unparalleled technical accuracy and performance for the most demanding applications.



Regulators for Oxygen Therapy: Compact Cilck-Style Regulator, Aluminum Body



- Single-stage adjustable flow range
- Click-in flow control
- Maximum inlet pressure 3000 psig (20700 kPa)
- Sintered filter for additional safety and to and extend regulator life
- 1-1/2" diameter contents gauge
- Hose barb outlet
- 6 year warranty

Gas	Part Number	Flow Range	Connector Type
Oxygen	WESOPA-820	0.25 - 15 LPM	CGA 870 Yoke

Praxair is proud to feature Western Medica branded products. For over 40 years, Western has been developing and supplying equipment for the control, storage, and transmission of high pressure gases to various markets. Western products are designed and manufactured to provide unparalleled technical accuracy and performance for the most demanding applications.



Regulators for Medical Gas Mixtures

Adjustable Gas Mixture Regulator for use with ‘K’, ‘T’ and Portable ‘E’ size Cylinders



- Single-stage with needle valve, adjustable delivery pressure to 50 psig (345 kPa)
- Chrome-plated brass body with all brass high pressure chamber
- Blood gas applications – adjusts to accurate bubble rate with needle valve
- Dual scale pressure gauge: psig and kPa
- 1700 SCFH (47 M3) maximum flow at 2000 psig (13800 kPa)
- Hose barb fitting for included 1/8” ID hose
- Sintered filter for additional safety and to extend regulator life
- 2” diameter gauges
- 6 year warranty

Gas	Part Number	Delivery Range	Connector Type
Carbon Dioxide and Oxygen Mixtures (CO ₂ not over 7.0%)	WESM1-280-PGB	0-50 psig	CGA 280 Nut and Nipple
	WESM1-880-PGB	0-50 psig	CGA 880 Yoke
Carbon Dioxide and Oxygen Mixtures (CO ₂ over 7.0%)	WESM1-500-PGB	0-50 psig	CGA 500 Nut and Nipple
	WESM1-940-PGB	0-50 psig	CGA 940 Yoke
Carbon Dioxide, Oxygen and Nitrogen Mixtures	WESM1-500-PGB	0-50 psig	CGA 500 Nut and Nipple
	WESM1-973-PGB	0-50 psig	CGA 973 Yoke
Lung Diffusion Mixtures	WESM1-500-PGB	0-50 psig	CGA 500 Nut and Nipple
	WESM1-973-PGB	0-50 psig	CGA 973 Yoke
Nitrogen and Oxygen Mixtures (O ₂ over 23,5%)	WESM1-280-PGB	0-50 psig	CGA 280 Nut and Nipple
	WESM1-890-PGB	0-50 psig	CGA 890 Yoke
Nitrous Oxide and Oxygen Mixtures (N ₂ O 47.5% to 52.5%)	WESM1-965-PGB	0-50 psig	CGA 965 Yoke
Nitrous Oxide and Oxygen Mixtures (N ₂ O 47.5% to 52.5%)	WESM1-280-PGB	0-50 psig	CGA 280 Nut and Nipple
Nonflammable, Noncorrosive Diagnostic and Medically Related Gas Mixtures	WESM1-500-PGB	0-50 psig	CGA 500 Nut and Nipple
	WESM1-973-PGB	0-50 psig	CGA 973 Yoke
Xenon and Oxygen Mixtures (O ₂ over 20.0%)	WESM1-280-PGB	0-50 psig	CGA 280 Nut and Nipple
	WESM1-880-PGB	0-50 psig	CGA 880 Yoke

Praxair is proud to feature Western Medica branded products. For over 40 years, Western has been developing and supplying equipment for the control, storage, and transmission of high pressure gases to various markets. Western products are designed and manufactured to provide unparalleled technical accuracy and performance for the most demanding applications.



Regulators for Heliox



Chrome Plated Brass Body

- Single-stage adjustable flow range
- 2" diameter gauges
- PTFE seat
- 1/4" hose barb outlet fitting
- Chrome plated brass bar stock body
- Stainless steel diaphragm
- Custom calibrated
- Maximum Inlet Pressure 3000 psig (20700 kPa/210 BAR)
- 10 micron sintered bronze filter

Gas	Part Number	Delivery Pressure	Connector Type
Helium 70% U.S.P / Oxygen 30% U.S.P.	CON305-9392-280	0-15 LPM	CGA 280 Nut and Nipple
	CON305-9392-890	0-15 LPM	CGA 890 Yoke
Helium 80% U.S.P. / Oxygen 20% U.S.P.	CON305-9391-280	0-15 LPM	CGA 280 Nut and Nipple
	CON305-9391-890	0-15 LPM	CGA 890 Yoke

Praxair is proud to feature medical regulators manufactured by CONCOA Products



Regulator for Flammable, Anaerobic Gas Mixtures



Chrome Plated Brass Body

- Single-stage adjustable flow range
- 2" diameter gauges
- PTFE seat
- Diaphragm valve 1/4" MPT outlet assembly
- Chrome plated brass bar stock body
- Stainless steel diaphragm
- Custom calibrated
- Maximum Inlet Pressure 3000 psig / 20700 kPa
- 10 micron sintered bronze filter

CONCOA's 302 Series regulators are intended for primary pressure control of noncorrosive, high purity or liquefied gases, or for applications where minor fluctuations in outlet pressure due to diminishing inlet supply can be tolerated.

Some of the features include increased serviceability and life, 316L stainless steel diaphragm, minimal purge requirements, smooth pressure changes, compact design, adjustable pressure ranges for a broad range of applications.

Typical applications: Gas and liquid chromatography, high purity carrier gases, span and calibration gases.

Gas	Part Number	Delivery Range	Connector Type
Carbon Dioxide, Hydrogen and Nitrogen Mixtures (CO ₂ not over 10%, H ₂ not over 10%, balance N ₂)	CON302-2331-350	0 - 50 psig	CGA 350 Nut and Nipple

Praxair is proud to feature medical regulators manufactured by CONCOA Products



Medical Gases and Equipment for MRI – United States

Everything in your Magnetic Resonance Imaging (MRI) room has to be carefully managed – including your medical gases and related equipment. Praxair can help you with your MRI-related gases needs by providing specially prepared oxygen cylinders, carts and regulators. Even specially prepared medical nitrous oxide and medical air cylinders are available for MRI.



Grab 'n Go® Vantage
(order on aluminum cylinder)



Oxygen (CGA 870)
(order on aluminum cylinder)



Air (CGA 950)
(order on aluminum cylinder)



Nitrous Oxide (CGA 910)
(order on aluminum cylinder)

Part Number	Description
ANT6105MRI	D/E Style Cylinder Cart for MRI use
VIC0781-3024	Medical Oxygen Regulator, 2-15 lpm, CGA 870, for MRI use
OX M-AEONGVNTG	Grab 'n Go Vantage AE Alum. Cylinder, Oxygen (Regulator Included)
WES PRX 9622	Medical Oxygen M-E Style Aluminum Cylinder for MRI use
WES PRX 9623	*Medical Air M-E Style Aluminum Cylinder for MRI use
WES PRX 9621	*Medical Nitrous Oxide M-E Style Aluminum Cylinder for MRI use

* Note – minimum order 12 cylinders

Medical Oxygen, Air, and Nitrous Oxide Cylinders

Order AE size cylinders for medical grade oxygen, air, and nitrous oxide. Aluminum cylinders are fitted with valves rated MRI contingent to 3 Tesla.

Oxygen Regulator

The regulator features adjustable flow rates for 0-15 lpm. It is fabricated from solid brass, and fitted with special gauges and accessories – for use in MRI environments.

Cylinder Carts

Convenient single and dual cylinder carts permit easy transport of cylinders from storage to the MRI room – and help protect the cylinder and regulator while in use.

Grab 'n Go Vantage Oxygen System

The Praxair *Grab 'n Go* Vantage Oxygen System, **when ordered on an aluminum cylinder**, is certified MRI Conditional to 3-Tesla, when located outside the MR bore. The system includes an integrated regulator, so there are no parts to assemble.

Adult Flowmeter



- Slim Line Brass Chrome Plated Body
- Polycarbonate inner and outer tubes provide greater accuracy and durability
- Optional power take-off units provide 50 psig (345 kPa) additional outlet pressure
- Double units for multi patient use from one wall outlet
- 6 year warranty

Gas	Part Number	Flow Range	Connector Type
Medical Air	WESFME604	1.0 - 15.0 LPM	DISS Handtight Nut
	WESFME606	1.0 - 15.0 LPM	Oxequip Style Adaptor
	WESFME607	1.0 - 15.0 LPM	Ohmeda Style Adaptor
	WESFME608	1.0 - 15.0 LPM	Puritan Style Adaptor
	WESFME609	1.0 - 15.0 LPM	Chemetron Style Adaptor
Oxygen	WESFME104	0.5 - 15.0 LPM	DISS Handtight Nut
	WESFME106	0.5 - 15.0 LPM	Oxequip Style Adaptor
	WESFME107	0.5 - 15.0 LPM	Ohmeda Style Adaptor
	WESFME108	0.5 - 15.0 LPM	Puritan Style Adaptor
	WESFME109	0.5 - 15.0 LPM	Chemetron Style Adaptor

Praxair is proud to feature Western Medica branded products. For over 40 years, Western has been developing and supplying equipment for the control, storage, and transmission of high pressure gases to various markets. Western products are designed and manufactured to provide unparalleled technical accuracy and performance for the most demanding applications.



Pediatric Flowmeter



- Slim Line Brass Chrome Plated Body
- Polycarbonate inner and outer tubes provide greater accuracy and durability
- Optional power take-off units provide 50 psig (345 kPa) additional outlet pressure
- Double units for multi patient use from one wall outlet
- 6 year warranty

Gas	Part Number	Flow Range	Connector Type
Oxygen	WESFME204	0.5 - 8.0 LPM	DISS Handtight Nut
	WESFME206	0.5 - 8.0 LPM	Oxequip Style Adaptor
	WESFME207	0.5 - 8.0 LPM	Ohmeda Style Adaptor
	WESFME208	0.5 - 8.0 LPM	Puritan Style Adaptor
	WESFME209	0.5 - 8.0 LPM	Chemetron Style Adaptor

Praxair is proud to feature Western Medica branded products. For over 40 years, Western has been developing and supplying equipment for the control, storage, and transmission of high pressure gases to various markets. Western products are designed and manufactured to provide unparalleled technical accuracy and performance for the most demanding applications.



Introduction to Suction Drainage Equipment



Suction Regulators:

These durable suction regulators are designed to provide broader ranges of use while simplifying your repair and parts replacement program. All regulators have common, readily interchangeable components, reducing the number of parts at a considerable cost savings. These regulators can be set to effectively limit the depth of vacuum (subatmospheric pressure) while still providing excellent air flows, thereby lessening the dangers of trauma. They are available in a variety of configurations and can be specifically marked for the areas of their intended use.

- Common, readily interchangeable parts to lower overall cost of ownership
- Suction range can be pre-set to limit potential for tissue trauma with high flow rates
- Can be labeled for areas of intended use

Surgical and Oral-Nasal-Tracheal (O.N.T.) Suction Regulators:

Western regulators are typically used in surgery or for aspirating mucus, blood, and other foreign bodies from the nose, mouth and upper respiratory tract. Regulators with the Nursery label are factory locked at 100mmHg. Tracheal and Suction Regulators are available in locked ranges below 200mm Hg, and are also available in Full Vac models without a locked range.

Remote Safety Interrupter and Integral Monitoring Gauge:

When using a suction-assisted drainage for the removal of gas, fluids, and small liberated solids from the stomach and upper intestinal tract, a Western Remote Safety Interrupter Assembly with integral monitoring gauge can be added between the regulator and the drainage collection unit. The Interrupter Assembly limits suction levels to 95mm Hg, and air flows of 1 to 3 lpm. The unit is so designed that when set above the 95mm Hg limit and the catheter becomes occluded, the unit will interrupt the drainage and cycle between 15 and 95mm Hg intermittently as long as the occlusion is present and the setting is too high. Provides excellent drainage in the 40-60mm Hg range and works well with double lumen vented gastric sump tubes.



Praxair is proud to feature Western Medica branded products. For over 40 years, Western has been developing and supplying equipment for the control, storage, and transmission of high pressure gases to various markets. Western products are designed and manufactured to provide unparalleled technical accuracy and performance for the most demanding applications.



Suction Regulators



Chrome Plated Brass or Aluminum Design

- Adjustable/lockable suction limits
- Infinite suction control within locked range
- 2-1/2" diameter gauge
- Clearly labeled for area of use
- On – Off control
- Simplified internal mechanical design
- Tracheal, Suction, Surgical: 0 – 200mm Hg
- Custom suction sets available on request

Brass Body	Aluminum Body	Regulator Description	Factory Locked Range and Air Flow
WESSR2101	WESSRA2101	Suction Dial, 1/4" FNPT	0 - 200mm Hg, Free Air Flow 0 - 80 L/Min
WESSR2103	WESSRA2103	Suction Dial, DISS Nut & Nipple	0 - 200mm Hg, Free Air Flow 0 - 80 L/Min
WESSR2104	WESSRA2104	Suction Dial, DISS H/T Nut and Nipple	0 - 200mm Hg, Free Air Flow 0 - 80 L/Min
WESSR2107	WESSRA2107	Suction Dial, Ohmeda Style Adaptor	0 - 200mm Hg, Free Air Flow 0 - 80 L/Min
WESSR2109	WESSRA2109	Suction Dial, Chemetron Style Adaptor	0 - 200mm Hg, Free Air Flow 0 - 80 L/Min
WESSR2301	WESSRA2301	Full Vac Dial, 1/4" FNPT	No Factory Lock, Free Air Flow 0 - 90 L/Min
WESSR2303	WESSRA2303	Full Vac Dial, DISS Nut and Nipple	No Factory Lock, Free Air Flow 0 - 90 L/Min
WESSR2304	WESSRA2304	Full Vac Dial, DISS H/T Nut and Nipple	No Factory Lock, Free Air Flow 0 - 90 L/Min
WESSR2307	WESSRA2307	Full Vac Dial, Ohmeda Style Adaptor	No Factory Lock, Free Air Flow 0 - 90 L/Min
WESSR2309	WESSRA2309	Full Vac Dial, Chemetron Style Adaptor	No Factory Lock, Free Air Flow 0 - 90 L/Min
WESSR2601	WESSRA2601	Tracheal Dial, 1/4" FNPT	0 - 160mm Hg, Free Air Flow 0 - 80 L/Min
WESSR2603	WESSRA2603	Tracheal Dial, DISS Nut and Nipple	0 - 160mm Hg, Free Air Flow 0 - 80 L/Min
WESSR2604	WESSRA2604	Tracheal Dial, DISS H/T Nut and Nipple	0 - 160mm Hg, Free Air Flow 0 - 80 L/Min
WESSR2607	WESSRA2607	Tracheal Dial, Ohmeda Style Adaptor	0 - 160mm Hg, Free Air Flow 0 - 80 L/Min
WESSR2609	WESSRA2609	Tracheal Dial, Chemetron Style Adaptor	0 - 160mm Hg, Free Air Flow 0 - 80 L/Min
WESSR2701	WESSRA2701	Nursery Dial, 1/4" FNPT	0 - 100mm Hg, Free Air Flow 0 - 30 L/Min
WESSR2703	WESSRA2703	Nursery Dial, DISS Nut and Nipple	0 - 100mm Hg, Free Air Flow 0 - 30 L/Min
WESSR2704	WESSRA2704	Nursery Dial, DISS H/T Nut and Nipple	0 - 100mm Hg, Free Air Flow 0 - 30 L/Min
WESSR2707	WESSRA2707	Nursery Dial, Ohmeda Style Adaptor	0 - 100mm Hg, Free Air Flow 0 - 30 L/Min
WESSR2709	WESSRA2709	Nursery Dial, Chemetron Style Adaptor	0 - 100mm Hg, Free Air Flow 0 - 30 L/Min

Praxair is proud to feature Western Medica branded products. For over 40 years, Western has been developing and supplying equipment for the control, storage, and transmission of high pressure gases to various markets. Western products are designed and manufactured to provide unparalleled technical accuracy and performance for the most demanding applications.



Remote Safety Interrupter with Integral Monitoring Gauge



Chrome Plated Brass Design

This unit is designed for use with Western’s suction regulator for suction-assisted drainage applications. Unit provides safety interruption at 95mmHg and will limit free air flow rates to between 1-3 L/Min.

By using this device for suction-assisted drainage applications, you can standardize your suction regulator inventory and simplify your maintenance program.

- Safety Interrupter limits suction levels to a maximum of 95mmHg
- No springs to go out of calibration
- 2-1/2” diameter integral monitoring gauge
- Chrome plated brass construction
- Unit can be connected directly to the suction regulator or to the collection container assembly

Part Number	Description
WESSR3501	Remote Safety Interrupter with Integral Monitoring Gauge and DISS-1220 Inlet and Outlet Fittings

Praxair is proud to feature Western Medica branded products. For over 40 years, Western has been developing and supplying equipment for the control, storage, and transmission of high pressure gases to various markets. Western products are designed and manufactured to provide unparalleled technical accuracy and performance for the most demanding applications.



Accessories for Suction Equipment



Cap and Bottle Assemblies

- Available in polycarbonate or plastic bottles
- Polycarbonate bottle and cap sold individually
- Plastic bottle and cap sold in case lots
- Polycarbonate bottles only sold in case lots
- Polycarbonate caps have DISS 1220 inlets
- Float ball assembly prevents liquid carryover

Part Number	Description
WESSR3121	16oz Polycarbonate bottle and cap, DISS 1220 outlet
WESSR3200	700cc Polycarbonate bottle and cap, hose tube outlet
WESSR3300	1200cc Polycarbonate bottle and cap, hose tube outlet
WESSR3400	Cap assembly only, hose tube outlet
WESSR3101	16oz Polycarbonate bottles, 12/case
WESSR3201	700cc Polycarbonate bottles, 12/case
WESSR3301	1200cc Polycarbonate bottles, 6/case
WESSR3401	1500cc Plastic cap and container, 40/case
WESSR3411	2500cc Plastic cap and container, 32/case

Praxair is proud to feature Western Medica branded products. For over 40 years, Western has been developing and supplying equipment for the control, storage, and transmission of high pressure gases to various markets. Western products are designed and manufactured to provide unparalleled technical accuracy and performance for the most demanding applications.



Cryogenic Products



Efficient & Effective Storage Systems: Cryobiology applications require the most thermally efficient storage systems. Praxair and Chart's combined years of cryogenic experience provide the added assurance your system will be designed and installed to suit the application. From engineering and layout to system installation and startup, Praxair can provide a single point of contact.

Security for Samples: The success for any liquid system starts at the point of use, or the application and works its way back to the cryogenic liquid storage. The Praxair and Chart team of engineers will conduct a total site survey to make sure all situations are considered for sample security. The Chart freezers offer full function alarm systems for low and high liquid level, high and low temperature for each of the 2RTD probes, LN2 supply, valve failure and power failure. Additional controller options allow for battery back-up systems for protection against electrical supply interruptions. The hot gas bypass system vents incoming gas until the liquid reaches the valve, minimizing the normal losses associated with filling from liquid containers.

The properly designed vacuum jacketed piping system minimizes the infiltration of heat into the system as a whole, which reduces operating costs. Chart vacuum insulated piping is the result of 30 years of continuous design and build improvement in the pursuit of manufacturing experience. The inner pipe in the system utilizes the same multi-layer component super insulation

which gives our cryogenic tanks world leading performance. Chart also pioneered bayonet type connections throughout Cryo-Bio applications, giving tight seals and higher performance with low LN2 usage. The T304 stainless inner-internal bellows vacuum pipe we offer is an industrial/commercial grade build to the same rigid requirements as ASME piping. Internal bellows eliminate contraction of the outer jacket, meaning no convoluted hosing is required.

Cost: We recognize that managing costs have required companies to improve operating efficiencies. A "cost of ownership (COO)" analysis is the best way to understand the impact of your purchasing decisions. Praxair can provide various COO models to help you evaluate the best gas, equipment and system decisions for your facility.

Examples include:

- Analyzing your current and future liquid and gas volume requirements will determine the most cost effective mode(s) of supply, dewars, microbulk, bulk tank, membrane or high pressure cylinders.
- Facility layout and logistics will impact piping system decisions.
- Mechanical freezers (energy, maintenance, life) vs. cryogenic storage.

At your request Praxair can work directly with architectural or consulting engineers for large expansions and new construction. Gas-handling equipment and delivery systems can be purchased directly from Praxair, eliminating extra costs typically associated with contractor purchases. System design services are available from the simplest to the most complex projects in addition to full turn-key packages.

The rewards of bringing innovative technologies to your facility can be tremendous. The Praxair/Chart team is ready to show you what it means to have a uniquely capable, enthusiastic, and resourceful supplier working on your behalf.

High Efficiency Freezers



- Specifically designed for vapor storage.
- Under lid temperature is at -190°C.
- 95% of system surface area enclosed by vacuum.
- High number of vials stored per sq.ft.
- Temperature measurement by RTD.
- 2 point calibration complies with GLP/GMP.
- Neck design maintains -190°C vapor storage.
- Durable metal lid and rotating int. tray.
- Low maintenance, all-stainless steel construction.
- Super-tough, durable casters.
- Rack stand.
- Step-up platform.
- 5 year vacuum warranty.

Part No.	Model	Liquid Nitrogen Capacity (liters)	Neck Opening (inches)	Height (inches)	Outer Diameter (inches)	Weight Empty (lbs.)
MVE11633452	810HE	370	12.5	47.3	32	475
MVE11360212	1520HE	756	17.5	53.2	42	600
MVE13800066	1830HE	1612	25	58.4	60	1500

Praxair features cryogenic storage products manufactured by Chart Industries, a leading global supplier of standard and custom-engineered low temperature equipment.



Stock Series Freezers



- Designed for storage in liquid nitrogen.
- Rotating tray for easy access to units.
- Sample retrieval ergonomically efficient.
- Provide secure, long-term sample storage.
- Metal lid construction for longer life.
- Tough, durable hinges.
- Vapor phase under lid temp. -125°C.
- Liquid phase under lid temp. -196°C.
- Low maintenance, all-stainless steel construction.
- Tough, durable casters.
- Optional vapor platform.
- 5 year vacuum warranty.

Part No.	Model	Liquid Nitrogen Capacity (liters)	Power Supply	Neck Opening (inches)	Height (inches)	Outer Diameter (inches)	Weight Empty (lbs.)
MVE10752871	808	230	24VDC	25	41.5	31	250
MVE10751676	1318	482	24VDC	35	47	42	410
MVE13817431	1842P-150	915	24VDC	25	44	60	1168
MVE13820972	1877P-2T	1400	24VDC	25	58	60	1600

Praxair features cryogenic storage products manufactured by Chart Industries, a leading global supplier of standard and custom-engineered low temperature equipment.



Cryo-Preservation Freezers



- Designed for either vapor or liquid storage.
- Large neck opening.
- Storage from 5200 to 39000 vials.
- Optional Battery back-up.
- Optional Gas by-pass optimizes fill efficiency.
- Metal lid construction.
- Tough, durable hinges.
- Vapor phase under lid temp. -125 C. Model 205 requires optional vapor sleeve to achieve -125 C.
- Liquid phase under lid temp. -196 C.
- Low maintenance, all-stainless steel construction.
- Tough, durable casters.
- Optional vapor platform.

Part No.	Model	Liquid Nitrogen Capacity (liters)	Power Supply	Neck Opening (inches)	Height (inches)	Outer Diameter (inches)	Weight Empty (lbs.)
MVE11004349	205	89	24VDC	16	46	23	194
MVE11905067	510	166	24VDC	20	44	24	577
MVE11922431	1839	673	24VDC	39	50	47	751

Praxair features cryogenic storage products manufactured by Chart Industries, a leading global supplier of standard and custom-engineered low temperature equipment.



Freezers



Freezer Features

- Durable, tamper-proof lid design
- Easy maintenance lid design
- Superior strength, lightweight aluminum construction
- High strength neck tube reduces liquid nitrogen loss
- Locking tab
- Color-coded canister/lid numbering system
- M128, Spider design – for easy retrieval and insertion of product canisters
- Insulation – MVE’s advanced insulation system provides maximum thermal performance
- 5 year vacuum warranty

Part No.	Model	Cap	NER (L)	Duration (days)	Neck Opening (in)	Overall Height (in)	Outside Diameter (in)	Weight Full (lbs)	Canister/ Container		0.5cc Straw cap.		2ml Vial cap.		
									Nbr	Ht. (in)	Dia. (in)	/Cane	/Bulk	/Cane	/Rack
MVE10719924	XC 47/11-6	47.4	0.39	76	5.00	26.5	20.00	120.40	6	11	4.00	4500	6216	1320	N/A
MVE10725435	XC 47/11-10	47.4	0.39	76	5.00	26.5	20.00	120.40	10	11	2.81	3500	5000	1050	N/A
MVE10743027	XC 34/18	34.8	0.18	123	3.50	26.6	18.20	96.00	6	11	2.81	2100	3000	630	N/A
MVE10719924	XC 47/11-6SQ	47.4	0.39	76	5.00	26.5	20.00	120.40	6 square	11	4.00	N/A	N/A	N/A	750
MVE11082646	XC Millennium 20	20.5	0.95	140	2.18	25.7	14.50	62.50	6	11	1.65	720	112	210	N/A
MVE9918039	XC 43/28	42.2	0.14	193	2.75	26.4	20.00	111.00	6	11	2.22	1260	1764	360	N/A
MVE9918069	XC 33/22	33.4	0.14	154	2.75	26.0	18.20	94.00	6	11	2.22	1260	1764	360	N/A
MVE9918449	XC 32/8	32	0.35	57	3.81	21.5	18.20	87.00	9	11	2.02	2520	3960	855	N/A
MVE9918539	XC 22/5	22.4	0.35	40	3.81	22.0	14.50	66.00	6	11	3.09	2400	3666	810	N/A

Praxair features cryogenic storage products manufactured by Chart Industries, a leading global supplier of standard and custom-engineered low temperature equipment.



Praxair, the Flowing Airstream design, Medipure and Grab 'n Go are trademarks or registered trademarks of Praxair Technology, Inc. in the United States and/or other countries. Other trademarks used herein are property of their respective owners. The information contained herein is offered for use by technically qualified personnel at their discretion and risk without warranty of any kind. © Copyright 2014, Praxair Technology, Inc. All rights reserved. Praxair Inc., Danbury, CT 06810-5113

Dewars



Dewar Features

- Easy maintenance lid design
- High strength neck tube reduces liquid nitrogen loss
- Advanced Chemical Vacuum Retention System – designed for superior vacuum performance over the life of the product
- Superior strength, lightweight aluminum construction
- Insulation – MVE’s advanced insulation system provides maximum thermal performance
- 5 year vacuum warranty

Part No.	Model	Net Capacity (liters)	Static Evaporation Rate (liters/day)	Neck Opening (in)	Overall Height (in)	Outside Diameter (in)	Internal Diameter (in)	Weight Empty (lbs)	Weight Full (lbs)
MVE9922219	LAB4	4	0.19	1.4	16.8	7.3	5.5	6	13
MVE9918079	LAB5	5	0.15	2.2	18.2	8.8	6.5	8	17
MVE10740281	LAB 10	10	0.18	2.2	21.5	10.3	8.3	13	31
MVE13492631	LAB 20	21	0.18	2	24.7	14.5	11.4	19	56
MVE9918099	LAB 30	32	0.22	2.5	24.1	17	14	27	84
MVE9918109	LAB 50	50	0.49	2.5	30.7	17	14	34	123
MVE11014070	SS Transfer unit	5		6	16.5	8	6	11	20
		2.5		6	11	8	6	8	12
		1.5		6	9	7	6	6	8

Praxair features cryogenic storage products manufactured by Chart Industries, a leading global supplier of standard and custom-engineered low temperature equipment.



Hand Held Cryo Freezing Devices

Praxair Health Care Services delivers *Medipure*® Liquid Nitrogen from one of the largest branch networks in United States. A local branch means you don't have to worry about running out of liquid nitrogen. And if you forget to re-order, our local professional team can arrange delivery to your door quickly.

Praxair's *Medipure*® products are produced in facilities registered with the FDA, in accordance with current Good Manufacturing Practices. Our Liquid Nitrogen NF is certified to National Formulary monograph and meets the requirements of CGA Standards.

To further augment our full range of cryogenic liquid products, we are glad to offer you the Cryogun and Mini-Cryogun from Brymill Cryogun Systems, a world leader in the design and manufacture of hand-held cryogenic equipment.

Some of the features of the Cryogen and Mini-Cryogen include:

- Manufacturer's three year warranty covers parts and labor
- Fully autoclavable
- Patented relief valve and pressure release system designed to reduce pressure build up in the flask
- A Delrin collar insulating user's hand from the cover
- All units fitted with new Delrin collar for extra stability
- Each unit supplied one A, one B, one D and two C apertures and the 20g bent spray
- Comprehensive range of sprays and probes available



Ordering Information:

Part Number	Description
BRYB-700	CRYOGUN, capacity 16 oz (500ml), static holding time 20-24 hrs, includes CD-ROM – The Complete Guide to Cryogenic Techniques
BRYB-800	MINI-CRYOGUN, capacity 10 oz (300ml), static holding time 10-12 hrs, includes CD-ROM – The Complete Guide to Cryogenic Techniques.
BRY605M	Safety gloves, medium, for cryogenic use.
NREF300	Lightweight face shield.

Medical Gases Pipeline Equipment Sales and Services

Sales:

All new and retrofit equipment is in compliance with NFPA 99, CGA, AHA, The Joint Commission, and OSHA requirements. Our full line of equipment includes:

Source Equipment: Air compressors, Vacuum pumps, Manifolds, Dryers, Filters, Dewpoint/CO monitors



Alarm Systems: Area and master alarms, Remote changeover alarms, Computer interface software.



Valves: Zone valve box assemblies, In-line valves.



Outlets: Medical gas outlets.



Repair Kits: Complete assemblies, Conversion kits, Rebuild kits.



Pipeline Equipment: Clean and bagged fittings, Pipe ID labels.



Services:

- Our technicians are trained to service most makes and models of medical gases pipeline equipment.
- Local technicians provide fast and efficient service in handling inspections and repairs.
- We provide temporary sources of gas and vacuum supply during shutdown periods.
- During construction, we coordinate with inspectors, electricians, plumbers, and other subcontractors.
- Comprehensive analytical testing service program.
- Certification for both new and existing systems.

Here are four good reasons to call Praxair Healthcare Services for your Medical Gases:

- A reliable source for all makes and models.
- Single-source equipment and service provider expedites and simplifies your procurement process.
- In house expertise in compressed gases.
- Accurate, consistent, reliable results... every time.

For more information or a needs assessment and cost estimate, call us at:

Northeast Division
 55 Old Ridgebury Road
 Danbury
 CT 06810
 Phone: 800-431-2460
 914-666-2990
 Fax: 914-666-9103
 www.praxair.com

Southeast Division
 2807 Gresham Lake Road
 Raleigh
 NC 27615
 Phone: 888-863-0500
 919-431-1352
 Fax: 919-431-8998
 www.praxair.com

Brazing Qualification and Certification Program

Praxair Healthcare Services offers an ideal brazing qualification and certification program for installing medical gas piping in healthcare facilities. The training and education provided meets the requirements of NFPA 99 and ASSE 6000 / 6010 standards. To stay current, individuals must be certified every time a new NFPA 99 standard is published, which is usually every three (3) years. All individuals, including licensed plumbers, are required to have this additional certificate to install medical gas piping systems.

Details of the program are as follows:

- The ASSE 6000 / 6010 standard required 32 hour educational program and written exam is presented by a certified P.I.P.E. (NITC – National Inspection Testing Certification) inspector.
- Brazing certificates are provided by P.I.P.E. (Piping Industry and Progress Education) or Praxair.
- Written brazing procedures and policies are provided for brazing medical gas piping as required by NFPA 99. These documents must be retained by the student.
- A practical test is provided, including testing and analyzing of brazed 1 ½” couplings.
- As stated by NFPA 99, to qualify for this program, four (4) years of documented practical experience in the installation of piping systems is required.
- Upon completion of the course, the trainee will meet ASSE 6010 requirements.

Brazing certification qualifies your personnel to do smaller installations in your facility. In addition, we offer *Medical Gas In-service Training* that teaches them to perform preventive maintenance on medical gas piping systems, and *Inspector Training* that enables them to properly supervise subcontractors.



For more information on our *Brazing Qualification and Certification Program*, *Medical Gas In-service Training*, and *Inspector Training*, call us at:

Northeast Division
55 Old Ridgebury Road
Danbury
CT 06810

Phone: 800-431-2460
914-666-2990

Fax: 914-666-9103

www.praxair.com

Southeast Division
2807 Gresham Lake Road
Raleigh
NC 27615

Phone: 888-863-0500
919-431-1352

Fax: 919-431-8998

www.praxair.com

Turnkey Solutions for Medical Gas Piping Systems

Our turnkey installations help ensure compliance with OSHA (Occupational Safety & Health Administration), The Joint Commission, NFPA (National Fire Protection Association), ASME (American Society of Mechanical Engineers), DHHS (Department of Health and Human Services), MGPHO (Medical Gas Professional Healthcare Organization), ASHE (American Society of Healthcare Engineers), ASPE (American Society of Plumbing Engineers), AWS (American Welding Society), and state and local codes.

Design:

Our turnkey solutions include designing upgrades or project expansions, installation and construction, shutdown management and brazing certification. In addition, we can provide:

- Plan and shop drawings.
- Specification and design review.
- Updated isometrics and CAD schematics.

Installation and construction:

Once the design is approved, we:

- Supply specified equipment.
- Install all the components including air compressors, vacuum pumps, manifolds, valves, outlets, and master and area alarms.
- Coordinate with inspectors, electricians, plumbers, and other subcontractors throughout the construction until the project is completed.



Here are three good reasons to call Praxair Healthcare Services for your Medical Gases Pipeline requirements:

- A reliable source for all specified equipment.
- Single-source equipment and service provider expedites and simplifies your procurement process.
- We are able to provide accurate, consistent, reliable results... every time.

For more information or a needs assessment and cost estimate, call us

Northeast Division
55 Ridgebury Road
Danbury
CT 06810

Phone: 800-431-2460
914-666-2990

Fax: 914-666-9103

www.praxair.com

Southeast Division
2807 Gresham Lake Road
Raleigh
NC 27615

Phone: 888-863-0500
919-431-1352

Fax: 919-431-8998

www.praxair.com

Maintenance Program for Medical Piping Systems

Praxair Healthcare Services offers a comprehensive program for medical gas pipeline systems in your facility that includes periodic testing, preventive maintenance, repairs, certification, utility system audits, decontamination services, engineering services, education and training.

Periodic Testing:

NFPA 99 and The Joint Commission require periodic testing for all medical gas systems.

- The medical pipeline system is tested for gas purity, leaks, and cross connections.
- Medical gas outlets and zone valves are inspected for conformance and performance.
- Master and local alarms are tested for proper function, activation, and labeling.
- All source supplies are inspected to NFPA 99 for proper conformance and function.

Preventive Maintenance:

- Scheduled to manufacturer's recommendations.
- Helps assure patient safety by reducing emergency repairs and unexpected service disruptions.

Service:

- Our technicians can install major brands and also perform repairs on most components of the medical pipeline system.
- Medical gas components are adjusted and calibrated to NFPA and OEM specifications.

Certification Program:

- Both new and existing systems must comply with NFPA, The Joint Commission, OSHA, state, and local codes.
- New systems: New systems must be installed and certified in strict compliance with codes. Leaks, cross connections, proper labeling, alarms, valves, manifolds, and outlets are verified with test gas. Shutdowns and system tie-ins are coordinated with the contractor. The system is then connected and retested for flow, purity, pressure, and cross connections, after which we issue final certification.
- Existing systems: We assess existing systems to ensure they are in compliance with acceptable NFPA, The Joint Commission, OSHA, state and local codes.

Utility system audits include:

- Periodic systems evaluations;
- Purity and concentration testing and
- Particulate analysis.

Decontamination services:

Purging is required for new systems. Existing piping sometimes requires purging to remove contaminants that get trapped in the system. Praxair can solve this problem with wash and purge services:

- The system is flushed to remove particulates, standing water, oil, and gaseous contaminants.
- Our decontamination program meets NFPA and CGA standards.

Engineering services:

Not having up-to-date drawings could be a major problem when you need to renovate, relocate, or upgrade your system. Using CAD/CAM software,



our engineers can:

- Recreate an accurate of schematic (2D) or isometric (3) drawings, identifying locations of existing gas systems including source equipment, piping location and sizing, sensors, alarms, valves, outlets, and gauges.
- Provide you with descriptive labeling for all the controls and valves shown on your schematics.

Education and training:

- Brazing certification – Our brazing certification course qualifies your personnel to do your own installations on smaller projects.
- Medical gas in-service training – Our in-service training teaches your personnel to perform preventive maintenance.
- Inspector training – Our inspector training enables your personnel to supervise subcontractors.
- Medical gas emergency preparedness – We provide emergency preparedness training for nurses and other personnel working with oxygen and other medical gases.

Here are four good reasons to enquire about our Maintenance Program for Medical Piping Systems:

- With decades of experience in bulk, manifold, and pipeline medical gas systems, we are well qualified to find and correct most of the deficiencies you are likely to encounter.
- We can evaluate your gas demand and recommend changes or upgrades to improve performance, prevent run outs, and lower costs.
- We can help you promote a safer working and clinical environment and improve the quality of patient care.
- All our procedures are in strict compliance with federal, state and local codes.

Environmental Monitoring Services

Praxair Healthcare Services offers you a full line of testing services to help you measure, monitor, and control employee exposure to hazardous vapors and indoor air quality throughout your facility – ensuring compliance with OSHA, The Joint Commission, DHHS, CAP, NIOSH, and ACGIH regulations.

On-site monitoring for hazardous chemical vapors including:

- Nitrous oxide and halogenated agents in anesthetizing areas.
- Ethylene oxide and glutaraldehyde in the central sterile department and other points of use.
- Formaldehyde, xylene, toluene, and other OSHA Z Table chemicals in the laboratory area.

Our surveys measure Time Weighted Average, Short-Term Exposure Levels, and Peak Exposure Levels. We also supply dosimeters, capable of detecting over 100 OSHA-regulated chemicals, for monitoring between inspections. Our assessment provides information on safe levels in accordance with OSHA requirements, and documentation required for The Joint Commission surveys. We assist you on corrective action required, and offer suggestions on how to reduce employee exposure to hazardous vapors in the workplace.

Indoor Air Quality including Sick Building Syndrome:

On-site audits for all areas where indoor air quality is likely to be suspect for pollutants such as:

- Moisture and bacteria.
- Volatile and semi-volatile organic compounds.
- Carbon dioxide and carbon monoxide.
- Formaldehyde.

Our technicians are familiar with OSHA and NIOSH standards. If there is a problem, they can pinpoint its source, offer solutions, and suggest corrective measures.

Isolation room testing:

- Negative/positive pressure testing
- Isolation room flow rates are tested and documented in accordance with the Center for Disease Control (CDC) and the Department of Health and Human Services (DHHS) recommendations. Praxair keeps written record of every inspection for 30 years as required by OSHA.



Here are seven good reasons why you should call Praxair Healthcare Services to help you measure, monitor, and control employee exposure to hazardous vapors:

- In house expertise in compressed gases.
- Safety station inspections.
- On call for analysis outside of normal business hours.
- Available twenty-four hour turnaround.
- Gas chromatography using remote sampling to identify a wider range of potential contaminants.
- Instrument calibration gases are NIST traceable.
- We aim to provide accurate, consistent, reliable results... every time.

For more information or a needs assessment and cost estimate, call us at:

Northeast Division
55 Old Ridgebury Road
Danbury
CT 06810

Phone: 800-431-2460
914-666-2990

Fax: 914-666-9103

www.praxair.com

Southeast Division
2807 Gresham Lake Road
Raleigh
NC 27615

Phone: 888-863-0500
919-431-1352

Fax: 919-431-8998

www.praxair.com

Site Gas Services



Why consider Praxair's Site Gas Services?

- Reduction in overall cost-to-serve
- Virtually eliminate lost cylinders
- Ensure supplemental oxygen is readily available throughout the hospital
- Reduce burden on hospital staff
- Special gases for testing and therapy are available in the most cost-efficient sizes
- Reduce costs associated with lost and broken equipment

The Site Gas Program will provide a single point of contact for all your gases related needs. From ensuring your gases are delivered to where you need them when you need them, our on-site personnel take care of inventory management, ordering/re-orders, performance metrics and joint planning.

Praxair ensures Just-In-Time delivery, set appropriate min/max inventory levels, eliminate obsolete stock, cylinder tracking, and provide equipment solutions. We streamline the order to payment process; simplifying the ordering and billing process, reduce accounts payable handling, and reduce payment costs and cycle times.

We help ensure your facility meets regulatory requirements including FDA, NFPA, OSHA, TPP and The Joint Commission. We will work with your facility to define and establish cost savings targets, end-user satisfaction levels and metrics based on error-free billing, on-time delivery, ease of ordering, productivity improvements, improvement in patient care and overall satisfaction.

For further information, and your no-obligation facility assess-

ment, contact your Praxair representative today.

Praxair's employee on-site at your facility

Praxair's Site Gas Services Program is designed for larger hospitals, and includes the services of a Praxair employee on-site. The program can be tailored to provide solutions in the following areas:

- Asset management
- Equipment services
- Transaction processing
- Safety, regulatory & environmental compliance
- Training
- Performance monitoring

For more information or a needs assessment and cost estimate, call us at:

Northeast Division
55 Old Ridgebury Road
Danbury
CT 06810

Phone: 800-431-2460
914-666-2990

Fax: 914-666-9103

www.praxair.com

Southeast Division
2807 Gresham Lake Road
Raleigh
NC 27615

Phone: 888-863-0500
919-431-1352

Fax: 919-431-8998

www.praxair.com

Analytical Services

Praxair Healthcare Services offers you a comprehensive analytical testing service program. Our experienced team of professionals in the Analytical Service Group is available to answer your questions through our 24-hour emergency response system, which includes on-call chemists.

We provide a twenty-four hour turnaround on gas analysis including:

- Oxygen (trace nitrogen levels)
- Nitrogen (trace oxygen levels)
- Nitrous Oxide (trace nitrogen and oxygen levels). Trace analysis of the variable gases such as carbon dioxide, carbon monoxide, methane, and total volatile hydrocarbons (TVHC)
- Liquid hydrocarbons (oil mist) in air
- Particulate quantifications
- Halogenated hydrocarbons
- Analytes are identified and quantified at levels from percent (%) to parts per million (ppm)

In addition, we quantify and identify unexpected contaminants in your medical gases piping. Such analyses include:

- Elemental analysis
- Melting point determination
- Metallurgical analysis
- Metals characterization
- Particle size determination
- Particulate quantifications
- Bacterial and fungi determination

Several commercial cleaning agents for oxygen service are available, some of which are halogenated solvents containing hydrocarbons. If you use these solvents for cleaning your medical piping, we offer two test methods to check for trace contaminants of halogenated hydrocarbons in the system after it has been cleaned and then flushed, usually with nitrogen:

- On-site Detector Tubes: These are usually calibrated for a particular chemical or chemicals.
- Gas Chromatography: Using our remote sampling system, we are able to test samples in our lab on a gas chromatograph which can specifically identify a wider range of potential contaminants at parts per billion (ppb) levels, well below the regulatory limit of 2 parts per million. Contact our chemists for details.

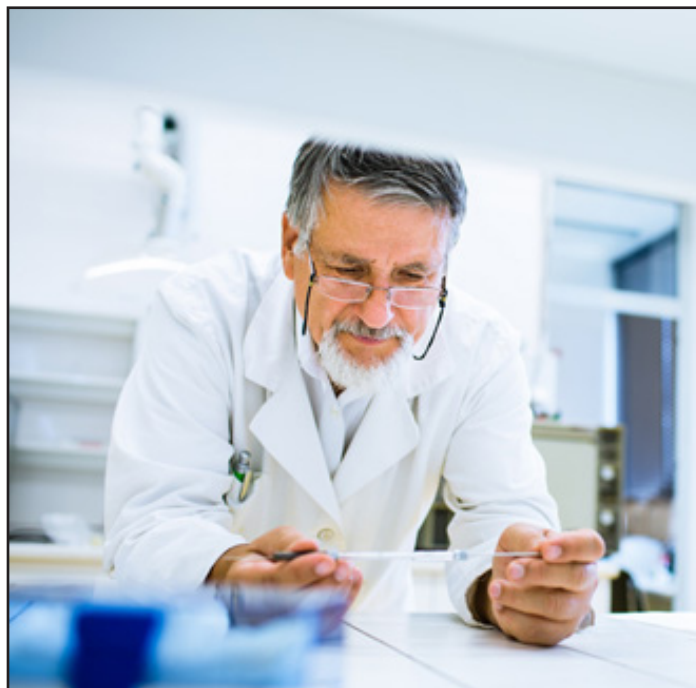

Here are six good reasons to call Praxair Healthcare Services for your medical gases piping systems sampling and analyzing needs:

- In-house expertise in compressed gases
- On call for analysis outside of normal business hours
- Available twenty-four hour turnaround
- Gas chromatography through remote sampling identifies a wider range of potential contaminants
- Instrument calibration gases are NIST traceable
- We aim to provide accurate, consistent, reliable results... every time

For more information or a needs assessment and cost estimate, call us at:

Northeast Division
55 Old Ridgeway Road
Danbury
CT 06810

Phone: 800-431-2460
914-666-2990

Fax: 914-666-9103

www.praxair.com

Southeast Division

2807 Gresham Lake Road
Raleigh
NC 27615

Phone: 888-863-0500
919-431-1352

Fax: 919-431-8998

www.praxair.com

Physicians and Dentists

Medical Gases for Primary Care:

Praxair Healthcare Services delivers *Medipure*[®] Oxygen USP and Nitrous Oxide USP to physicians and dentists from one of the largest branch networks across the country. A local branch means you don't have to worry about running out of product. And if you forget to re-order, our local professional team can arrange delivery to your door quickly.

Medipure[®] means assurance for you that Praxair's medical gases are produced in facilities registered with the FDA, and packaged to meet CGA standards.

And now with Praxair's new Grab 'n Go-Vantage, you don't have to buy or maintain a regulator to provide oxygen in an emergency. With Praxair's Grab 'n Go-Vantage Advanced Respiratory System, the regulator is pre-attached to make it less complicated to use in an emergency. This single integrated unit provides Oxygen USP with both regulator and contents gauge built right onto the cylinder. You don't have to find a wrench and attach a regulator to the oxygen cylinder prior to use. One-knob operation makes Grab 'n Go systems easy to use. Straight forward multimedia training material is available for your staff.

High-Pressure Cylinder Size Chart:

High-Pressure Cylinders

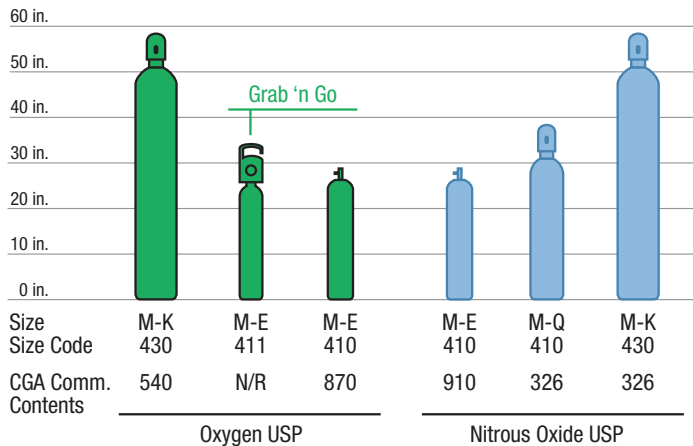

Oxygen and Nitrous Oxide Cylinder Data:

Part Number	Description
OX M-EGNGVNTG	Grab 'n Go-Vantage Oxygen, 25 cu ft
OX M-E	ME Oxygen Cylinder, 25 cu ft
OX M-K	K Oxygen Cylinder, 249 cu ft
NS M-E	ME Nitrous Oxide Cylinder, 6.4 lb
NS M-Q	Q Nitrous Oxide cylinder, 20 lb
NS M-50K	Nitrous Oxide Cylinder, 50 lbs
NS M-64K	Nitrous Oxide Cylinder, 64 lbs

Cryogenic Products for Primary Care

Cryogenic Products:

Praxair Healthcare Services delivers *Medipure*® Liquid Nitrogen to physicians' offices from one of the largest branch networks across the country. A local branch means you don't have to worry about running out of product. And if you forget to re-order, our local professional team can arrange delivery to your door quickly.

Our Liquid Nitrogen NF Grade is certified to the National Formulary monograph.

For cryogenic storage, MVE-brand high efficiency, super-insulated dewars are the most convenient, economical way to store and dispense liquid nitrogen. They can be fitted with pour spouts or pressurized dispensing devices to aid in the transfer of liquid.



Liquid Nitrogen Dewars:

Part Number	Description
MVE10740281	LAB 10 Dewar
MVE13492631	LAB 20 Dewar
MVE9918099	LAB 30 Dewar

Dewar Accessories:

Part Number	Description
MVE9711589	LAB 10 Dipper
MVE10668101	LAB 10 Discharge Device
MVE9720729	LAB 10 Pour Spout
MVE9711619	LAB 20 Dipper
MVE9711909	LAB 20 Pour Spout
MVE10667802	LAB 20 Discharge Device
MVE9711679	LAB 30 Swivel Dipper
MVE 10668004	LAB 30 Discharge Device
MVE9711929	LAB 30 Pour Spout
PRXUF21-IN3	Transfer Hose, 3 ft.
MVE10615885	Phase Separator
MVE9717129	Cryo gloves, large
MVE10464394	Cryo apron
NREF400	Standard faceshield
CRESS110	Safety glasses

Cryo Apron



Cryo Gloves



Face Shields



Phase Separators



Accessories for Physicians and Dentists

Praxair Healthcare Services offers a wide range of gas handling equipment such as oxygen regulators, wrenches, cylinder carts, wall mounting brackets and resuscitators to help you handle your medical gases safely and efficiently.

From our extensive line of medical gas-related products, we have listed some of the popular items typically ordered for physician and dental offices. Praxair is a leading national supplier of medical gases and equipment. For items not shown, please contact us.

Order these and other products by calling your local branch or 1-800-225-8247, or order on-line at Praxair Express <https://express.praxair.com/login/login.asp>



Hose Assemblies



Oxygen Regulators



Cylinder Carts



Wrenches



Swivel Connector, Nut & Nipple for Regulators



Wall brackets



Manual Resuscitator



Part Number	Description
WESM1-870-15FG	Oxygen Regulator, Adjustable 2-15 L/min for M-E size cyl
WESM1-540-15FG	Oxygen Regulator, Adjustable 2-15 L/min for K size cyl
WESMCW-3PC	Plastic wrench, ME size cyl with chain
WESM24-45P	Swivel Connector, Nut and Nipple for Regulator
ANT6110	Cart, Large Cylinder (K, Q size)
ANT6105	Cart, Small Cylinder (ME size)
ANTWB-100	Wall Bracket for K size cylinder
ANTWB-200	Wall Bracket for 2 K size cylinders
HUD5372	Manual Resuscitator w/mask and tubing
WESPX1000	Nasal Cannula with tubing (7 ft)
AMVHS03UODDFC4	Hose Assembly, Oxygen, 3 ft, DISS Female by DISS Female ends
AMVHS04UODDFC4	Hose Assembly, Oxygen, 4 ft, DISS Female by DISS Female ends
AMVHS03U2DFDFC4	Hose Assembly, Nitrous Oxide, 3 ft, DISS Female by DISS Female ends
AMVHS03U2DFDFC4	Hose Assembly, Nitrous Oxide, 4 ft, DISS Female by DISS Female ends

Cylinder Valve Connections for Medical Compressed Gases



Threaded Outlet Type Large Cylinder Valve.
For “T”, “K”, “S”, and “Q” style cylinders.



Post Type Pin Indexed Small Cylinder Valve.
For “E” and “D” style cylinders.

Praxair follows CGA V-1, Compressed Gas Association Standard for Compressed Gas Cylinder Valve Outlet and Inlet Connections used on medical compressed gases.

The Compressed Gas Association (CGA) has established a standard detailing dimensions for the manufacture of cylinder valve inlet and outlet connections, designed to minimize the possibility of misconnections. Although the main purpose in standardizing cylinder valves is to prevent non-compatible gas interconnection, relying on the valve outlet as the sole method of preventing such an interconnection is not advisable. The primary means of identifying cylinder contents must be by means of the chemical name or commercially accepted name, legibly indicated on the cylinder.

Post Type Pin Indexed Yoke Valves

Post type pin indexed yoke valves for medical gases are designed such that pins in the yoke and corresponding mating holes in the valve body preclude unintended connections. Post type pin indexed valves require a yoke fitting that compresses a single washer against the flat valve face to ensure a gas tight seal. The yoke is equipped with two pins (except CGA 965) that fit into corresponding recesses located on the valve face, minimizing the possibility for error since both parts must match to make a connection. **Never remove pins from yoke fittings.**

Praxair supplies a new gasket/washer with each cylinder equipped with a post-type valve to ensure a gas-tight connection with the gas regulating device.

The gasket provided is designed for single-use and must be discarded every time a regulator or cylinder is changed. When changing the regulator or cylinder, remove the dust cover, “crack” the cylinder valve (open the cylinder valve momentarily and then

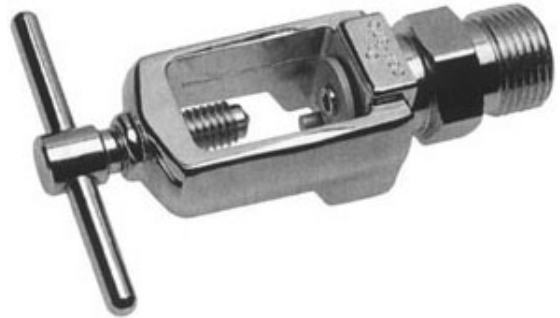

Typical cylinder yoke

close it), and never use more than one gasket to provide the gas-tight seal. Always refer to the manufacturer’s instructions for attaching the regulator to the cylinder.

Pin-Index Hole Locations for Post-Type Cylinder Valves

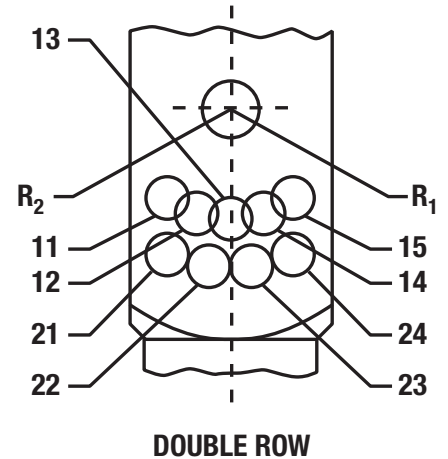
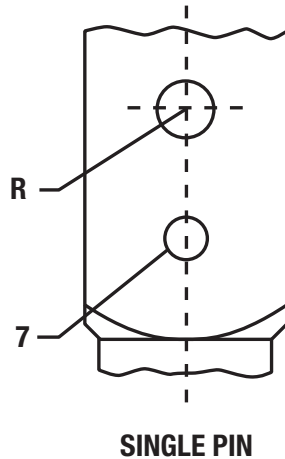
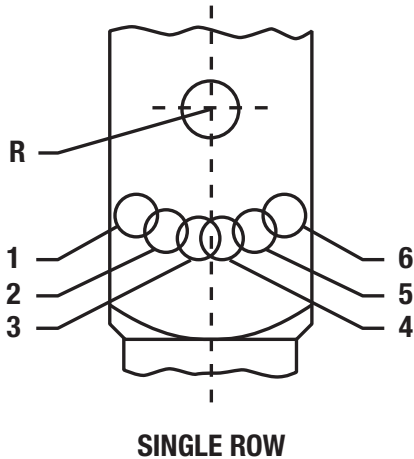

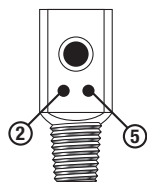

CGA CONNECTION NO. 870
Flush Outlet Yoke Connection
Oxygen

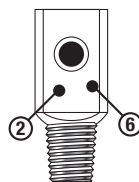

CGA CONNECTION NO. 880
Medical Cylinder Yoke Connection
Carbon Dioxide-Oxygen Mixtures
(CO₂ < or = 7.0%)

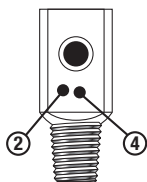

CGA CONNECTION NO. 890
Medical Cylinder Yoke Connection
Helium-Oxygen Mixtures (He < or = 80.0%)
Xenon-Oxygen Mixtures (Xe < or = 80.0%)
Oxygen-Nitrogen Mixtures (O₂ > 23.5%)

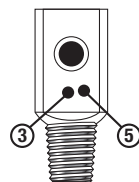

CGA CONNECTION NO. 910
Medical Cylinder Yoke Connection
Nitrous Oxide

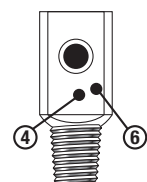

CGA CONNECTION NO. 930
Medical Cylinder Yoke Connection
Helium
Helium-Oxygen Mixtures (He > 80.0%)

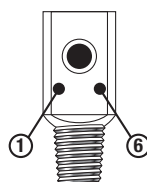

CGA CONNECTION NO. 940
Medical Cylinder Yoke Connection
Carbon Dioxide
Carbon Dioxide-Oxygen Mixtures
(CO₂ > 7.0%)

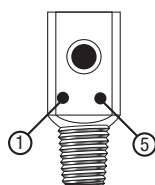

CGA CONNECTION NO. 950
Medical Cylinder Yoke Connection
Air

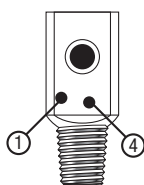

CGA CONNECTION NO. 960
Medical Cylinder Yoke Connection
Nitrogen

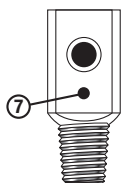

CGA CONNECTION NO. 965
Medical Cylinder Yoke Connection
Nitrous Oxide-Oxygen Mixtures
(N₂O 47.5 to 52.5%)

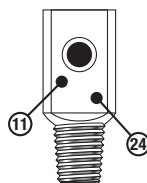

CGA CONNECTION NO. 973
Medical Cylinder Yoke Connection
Carbon Dioxide-Oxygen-Nitrogen Mixtures
Lung Diffusion Mixtures
Nonflammable, Noncorrosive Diagnostic and
Medically Related Gas Mixtures

Threaded Outlet Type Valves With Handwheels

Threaded outlet valves for large cylinders are separated into four basic divisions – Internal Thread (INT), External Thread (EXT), Right Hand Thread (RH), and Left Hand Thread (LH). Further separation is made within each division by varying the diameter of the threads, and the size and shape of seats and nipples for any given thread size.

Where size permits, it is recommended that valves, nuts and nipples be marked with the appropriate CGA number. Left Hand Threads (LH) are identified by a V-groove in the hexagonal nut. Each outlet provides for screw threads which do not seal, but merely hold the nipple against a seat in the valve outlet or against a washer.

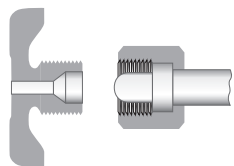

CGA CONNECTION NO. 280
 .745-14NGO-RH-EXT
 Carbon Dioxide-Oxygen Mixtures
 ($\text{CO}_2 < \text{or} = 7.0\%$)
 Oxygen-Nitrogen Mixtures ($\text{O}_2 > 23.5\%$)
 Oxygen-Nitrous Oxide Mixtures
 ($\text{N}_2\text{O} 47.5 \text{ to } 52.5\%$)
 Helium-Oxygen Mixtures
 ($\text{He} < \text{or} = 80\%$)
 Xenon-Oxygen Mixtures
 ($\text{Xe} < \text{or} = 80\%$)

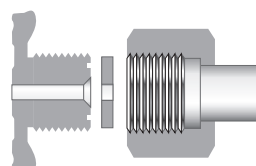

CGA CONNECTION NO. 320
 .825-14NGO-RH-EXT (Flat Nipple)
 Carbon Dioxide

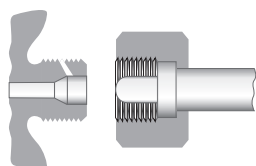

CGA CONNECTION NO. 326
 (Formerly 1320)
 .825-14NGO-RH-EXT
 (Small Round Nipple)
 Nitrous Oxide

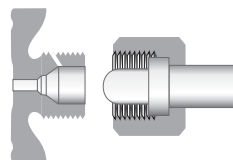

CGA CONNECTION NO. 346
 .825-14NGO-RH-EXT
 (Large Round Nipple)
 Air

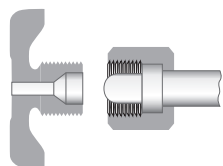

CGA CONNECTION NO. 500
 .885-14NGO-RH-INT (Bullet Nipple)
 Carbon Dioxide-Oxygen Mixtures
 ($\text{CO}_2 > 7.0\%$)
 Helium-Oxygen Mixtures
 ($\text{He} > 80.0\%$)
 Lung Diffusion Mixtures
 Nonflammable, Non-corrosive Diagnostic and Medically Related Gas Mixtures

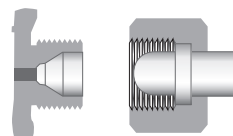

CGA CONNECTION NO. 540
 .903-14NGO-RH-EXT
 Oxygen

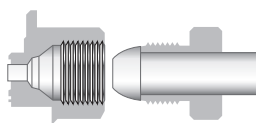

CGA CONNECTION NO. 580
 .965-14NGO-RH-INT
 Helium
 Nitrogen
 Xenon

Cylinder Size and Color Chart Medical Applications



Medical Air, U.S.P. Grade

CGA 346 and CGA 950 (E and D sizes only)

(Yellow)

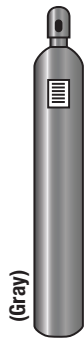

Carbon Dioxide (CO₂) U.S.P. Grade

CGA 320 and CGA 940 (E and D sizes only)

(Gray)

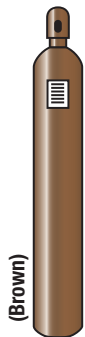

Helium (He), U.S.P. Grade

CGA 580 and CGA 930 (E and D sizes only)

(Brown)



Nitrogen (N₂), NF Grade

CGA 580 and CGA 960 (E and D sizes only)

(Black)

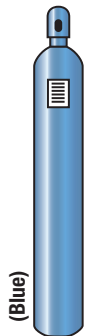

Nitrous Oxide (N₂O), U.S.P. Grade

CGA 326 and CGA 910 (E and D sizes only)

(Blue)



Oxygen (O₂), U.S.P. Grade

CGA 540 and CGA 870 (E and D sizes only)

(Green)

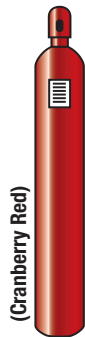

Specialty Gas Mixtures

Various CGAs

(Cranberry Red)

Caution:

Do not use cylinder color to identify gases.

Always read labels to identify contents. CGA connection may be used as a secondary check of contents.

High Pressure Cylinders

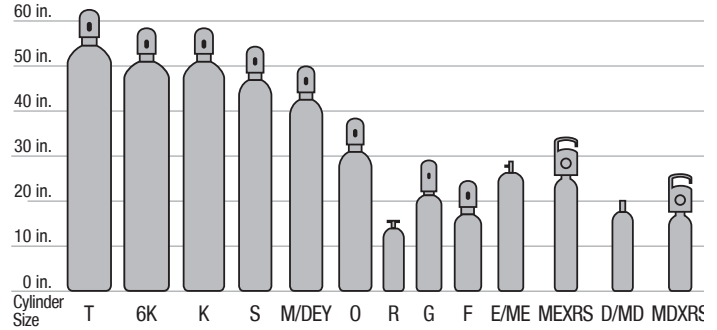

Cryogenic Containers

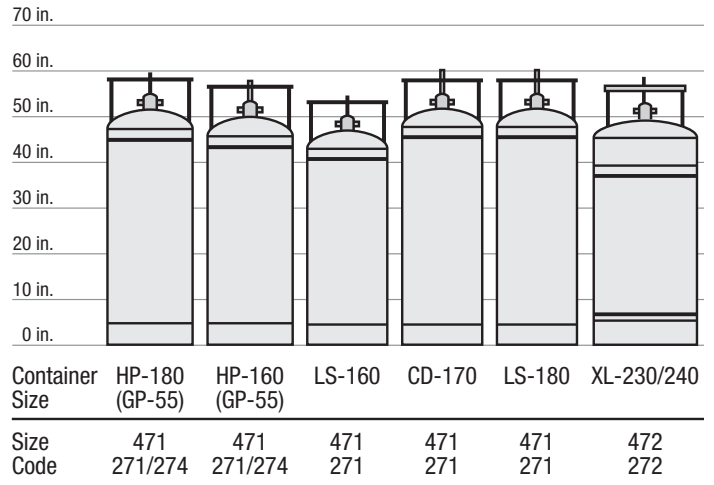

Product	Gas (Use)	Liquid
Nitrogen – Cryogenic Liquid	CGA 580	CGA 295
Oxygen – Cryogenic Liquid	CGA 540	CGA 440
Carbon Dioxide – Refrigerated Liquid	CGA 320	CGA 622
Nitrous Dioxide – Refrigerated Liquid	CGA 326	CGA 326

LD Series Dewars

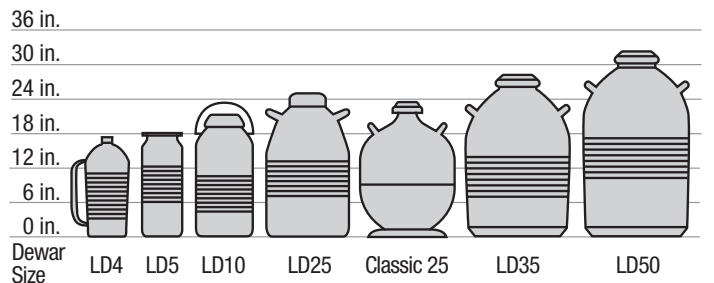

General Safety Information

Moving Cylinders and Containers

Cylinders and containers must always be moved carefully. Mishandling that results in a damaged valve or ruptured cylinder can expose personnel to the hazards associated with these gases. In addition, most gas cylinders are heavy and bulky. A cylinder striking someone or pinching a finger, toe, or other extremity is a common cause of injury. For these reasons, all cylinder handlers must always wear certain minimum personal protective equipment prescribed by OSHA.

- Gloves to protect hands against common pinching injuries.
- Safety glasses to protect eyes against injuries associated with pressure release
- Safety shoes with metatarsal supports to protect against foot injuries from falling cylinders.

Before moving the cylinder to the storage area or point of use or before returning the cylinder to the supplier, ensure the following:

- The outlet valve is fully closed.
- The outlet valve dust plug or pressure cap is on tight for cylinders equipped with these protection devices (where supplied).
- The valve protection cap is properly secured in place on cylinders with neck threads (where supplied). **Note:** *Valve caps must always be in place while moving or transporting cylinders or when they are in storage.*

While moving full or empty cylinders:

- Always use carts or hand trucks designed for this purpose.
- Never drop cylinders or allow them to strike each other violently.
- Never lift cylinders by the cap or with a lifting magnet.

After moving a cylinder to its point of use, secure the cylinder in place. Use cylinder stands, clamps, or other securing devices recommended by your supplier.

Storing Cylinders and Containers

Storage of compressed gas cylinders and cryogenic liquid cylinders is governed by codes of the National Fire Protection Association (NFPA). Local codes may also apply. Know and obey codes governing storage at your location.

Safe Practices

In general, store cylinders so they can't be easily toppled over. Remember, danger exists not only from accidental release of gas by cylinders damaged in a fall but also from their striking someone and causing injury. Store cylinders upright in compact groups, interlocking them so that each cylinder physically contacts those around it. Do not stand cylinders loosely or in a haphazard manner. A single cylinder that topples over can create a domino effect causing other cylinders to fall. Single cylinders should be secured in place or on a cylinder cart so they can't be easily knocked over. Keep stored cylinders out of high traffic areas. Do not store them near the edges of platforms. Avoid storage in areas where there are activities that could damage or contaminate the cylinders. Electric arc welding can destroy the integrity of cylinder metal if a welder carelessly strikes an arc on a cylinder. Overhead hoists can drip oil or grease on cylinders, contaminating them. Never store cylinders with flammable materials.

Opening and Closing Valves

Observing a few simple rules when opening and closing valves can prevent damage to valves and equipment and add years of useful service life to the valves. Praxair supplies a new gasket/washer with each cylinder equipped with a post-style valve to ensure a gas-tight

connection with the gas regulating device. The gasket provided is designed for single-use and must be discarded every time a regulator or cylinder is changed. When changing the regulator or cylinder in a post-style valve, remove the dust cover and never use more than one gasket to provide the gas-tight seal. Always refer to the manufacturer's instructions for attaching the regulator to the cylinder. The proper way to open any cylinder valve is to first "crack" the valve (open the cylinder valve momentarily and then close it), then open it slowly by turning the handle or stem counterclockwise. This allows equipment to gradually adjust to full pressure. Stop turning as soon as there is any resistance. Turning the valve handle or stem too far in the open position can jam the stem causing damage and leaks and preventing later closure. Likewise, overtightening when closing a valve can damage or permanently distort the seat and result in leakage.

Receiving Cylinders – External Inspection

Personnel responsible for receiving cylinders should perform an external inspection on all packages before moving them to the point of use or to the storage area. Basic guidelines for performing this inspection are as follows:

Read the cylinder labels to be sure that the gas is what you ordered and that you understand the hazards associated with the product. Remember, the label is the only means of identifying the product in the cylinder. Never identify the product by the color of the cylinder. A secondary check of contents may be made by using the CGA connection on the valve.

Check the TC/DOT cylinder markings to be sure you understand the pressures contained in the cylinders.

Thoroughly inspect the cylinders for any obvious damage. The cylinder surface should be clean and free from defects such as cuts, gouges, burns and obvious dents. Such damage could weaken the cylinder metal, creating a danger of failure, or it could make the cylinder unstable and more likely to tip over. Make sure the cylinder stands steady on its base and does not wobble.

Cylinders with neck threads should have a cap in place over the valve. Remove the cap by hand. Never use a screwdriver, crowbar, or other leverage device to remove the cap. You could accidentally open the valve or damage it.

Check the cylinder valve to be sure it is not bent or damaged. A damaged valve could leak or fail, or it might not make a tight connection when the cylinder is placed into use. Make sure the valve is free from dirt and oil, which could contaminate the gas. Dirt particles propelled in a high velocity gas stream could cause a spark, igniting a flammable gas. Oil and grease can react with oxygen and other oxidizers, causing an explosion.

If any cylinder is received with missing or unreadable labels and markings; visible damage; an unstable base; a missing cap; or a bent, damaged, or dirty valve, do not use the cylinder. Contact your supplier and ask for instructions.

Testing for Leaks

After completing the external inspection, proceed as follows:

- Test the cylinder valve for leaks using the leak test method approved by your employer. If you detect leakage, follow the employer's procedures for handling leaking cylinders. **Note:** *It is normal for cryogenic liquid cylinders to vent through their relief valves to relieve excess pressure build up due to heat leak. This venting is not a leak.*
- If no leak is detected, secure the cylinder valve cap in place before moving the cylinder to the point of use or to the storage area.



Praxair Healthcare Services
39 Old Ridgebury Road
Danbury, CT 068110-5113
USA

Telephone:
1-800-PRAXAIR
(1-800-772-9986)

Fax:
1-800-772-9985
(716) 879-2040

Internet: www.praxair.com/healthcare

Praxair, the Flowing Airstream design, Grab 'n Go, and Medipure are trademarks or registered trademarks of Praxair Technology, Inc. in the United States and/or other countries.

The information contained herein is offered for use by technically qualified personnel at their discretion and risk without warranty of any kind.

PXCATV1 1K